

SUBJECT: RADIO POWER SUPPLY MODIFICATION INSTRUCTIONS

The following procedure should be followed when implementing Radio Power Conversion Kit 1099527 (see below).

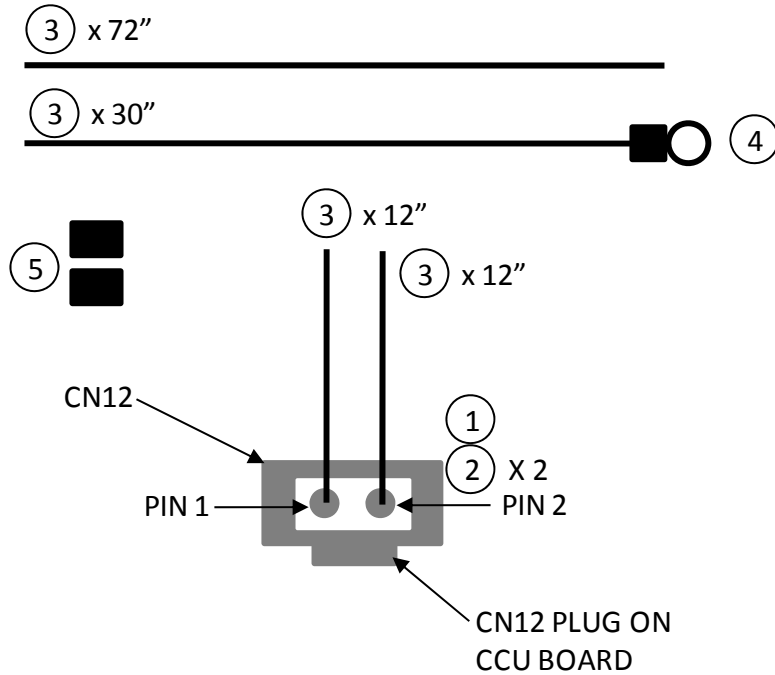

POWER CONVERSION RADIO KIT - SC300

Item	Qty	Webb P/N	Description
1	1	C1094527	CONNECTOR - RECT 3 POS 2.95mm
2	2	C1094528	CONNECTOR - SOCKET 016-020
3	132"	C1002573	WIRE - HOOKUP # 18 AWG - BLACK
4	1	C1016655	TERMINAL - #18-22 AWG 1/4"
5	2	N/A	BUTT SPLICE - ELECTRONICS COMPONENT

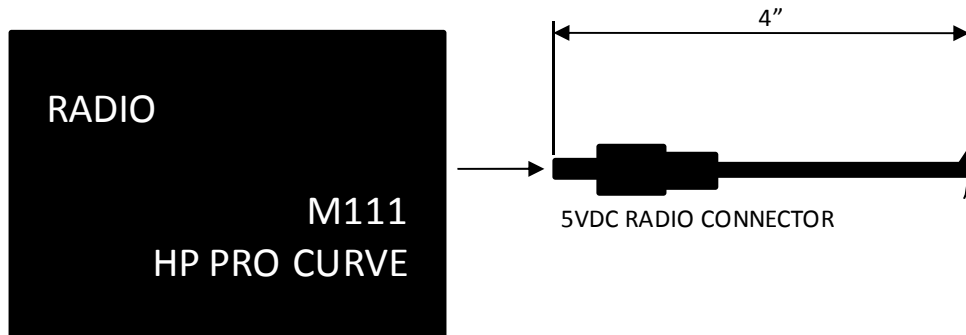

- Step 1. Unplug vehicle battery.
- Step 2. Disconnect radio and cut connector approximately 4" from end.

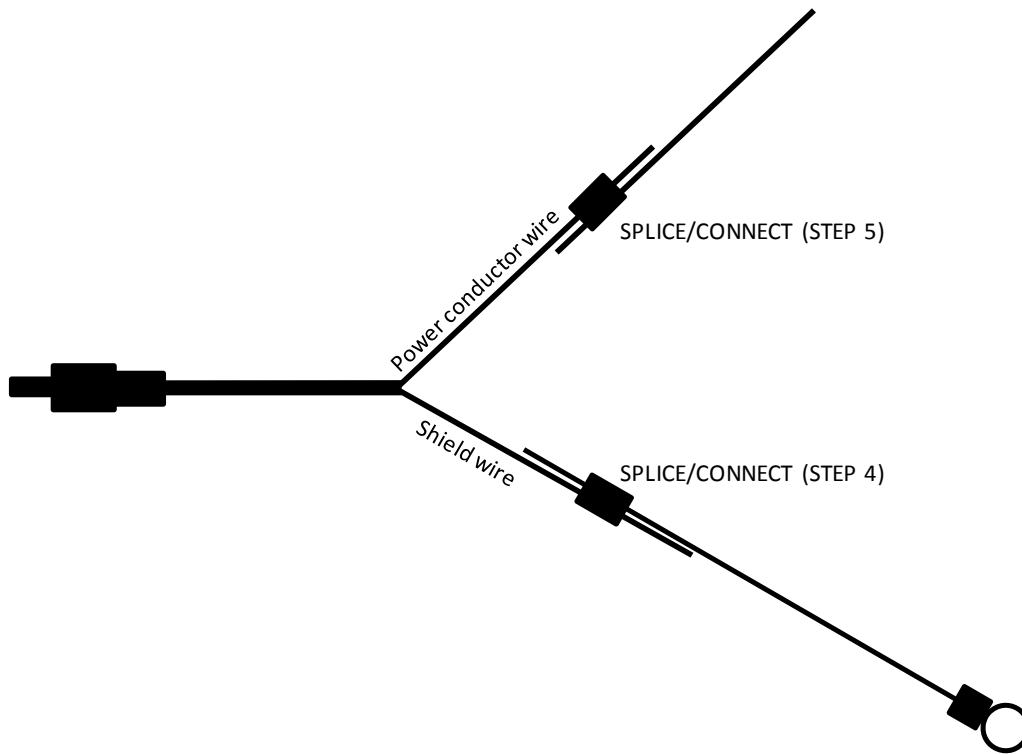

Step 3. Split wire and strip back both shield and power conductor.

Step 4. Splice (solder/connector) and heatshrink wire with ring terminal (item 4) to shield wire (or radio power supply cable).

Step 5. Splice (solder/connector) and heatshrink a 72" segment of wire (item 3) to power conductor (or radio power supply cable).

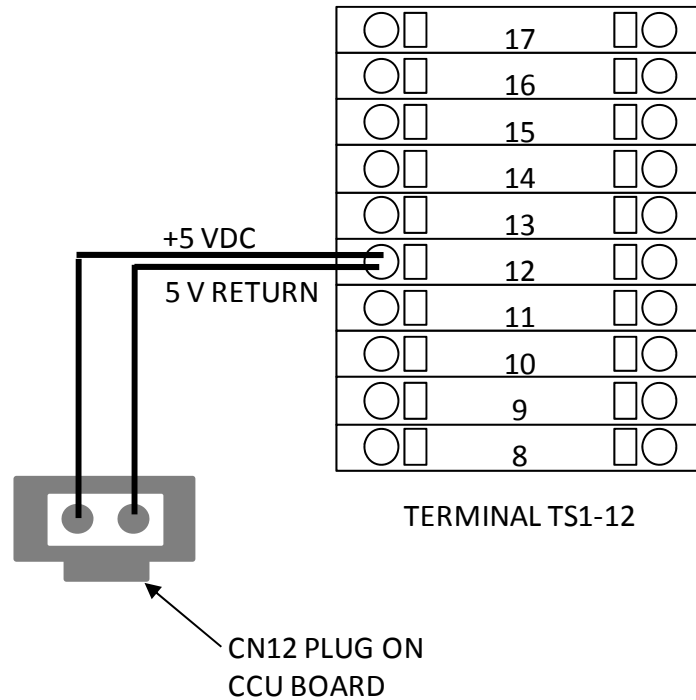

Step 6. Unplug factory jumper plug from CN12 on the CCU board.

Step 7. Attach new plug connector to same location.

Strip and connect each end to an open terminal block.

Note: Both wires go to the same terminal, so it still acts as a jumper circuit.

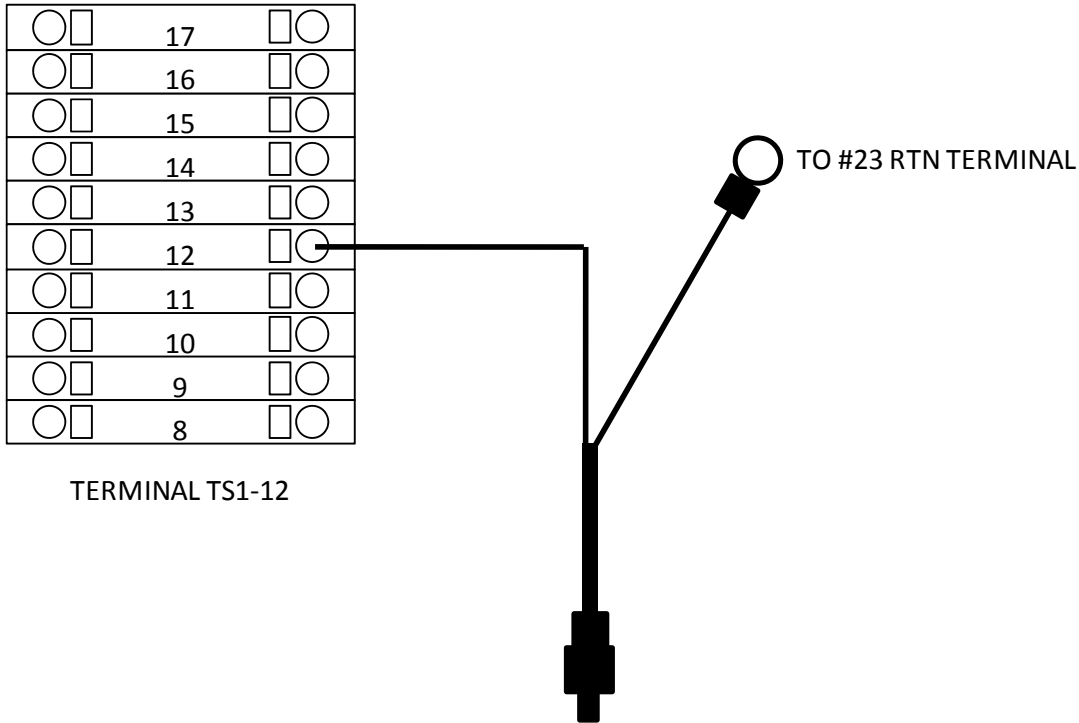

- Step 8. Attach ring terminal to #23 GND buss.
- Step 9. Connect other end of wire from power conductor (insulated wire in radio power supply cable) to other end of terminal strip.
- Step 10. Connect CN12 plug to CCU board.
- Step 11. Reconnect battery and start vehicle.