

A blue car body is shown on a conveyor system in a factory. The car is positioned on a metal grate floor, and the background shows the industrial structure of the plant with overhead lighting.

WIDE WING DOG MAGIC[®]

POWER & FREE

**Overhead and Inverted
CONVEYOR SYSTEMS**

DAIFUKU



Contents:

Power & Free Features	2-3
Wide Wing	4
Rivetless Chain.....	5
Overhead Track Configuration.....	6-7
Inverted Track Configuration	8-9
Load Bar Arrangements.....	10
Switches, Stops, and Lifts	11
Drives, Takeups, and Controls.....	12
Support Services	13



WIDE WING DOG MAGIC[®]

POWER & FREE

Overhead and Inverted Conveyor Systems

Wide Wing Power & Free conveyors are specially designed to accommodate industrial applications which demand a higher degree of versatility and adaptability than conventional conveyors can offer. Variable chain speeds, high speed indexing, recirculation of products, balancing of operations, and surge and stripping capabilities provide maximum material flow and the cost-effectiveness required in Flexible Manufacturing Systems. These features make Wide Wing Power & Free conveyors one of the most useful and successful manufacturing tools available today.



A broad range of manufacturing requirements are easily handled by Wide Wing Dog Magic Power & Free conveyors. These features allow the conveyors to interface smoothly with automatic work stations, loading and unloading equipment, and a variety of production robots.

Innovative design features, such as high density accumulation and batch movement, conserve valuable floor space. Power & Free conveyors are designed to transport materials and products efficiently through a variety of manufacturing and assembly processes.

Simple elevation changes permit maximum use of valuable plant floor space and can eliminate costly lift and transfer devices. The conveyor can go up and over aisles for production movement, without interrupting worker or fork truck traffic.

Carrier identification systems, including Electro-Mechanical, radio frequency (RF) and optical, are available to allow tracking of every carrier in the system.



Load Center or Speed Variations

Carriers can be switched to an alternate power chain to maintain predetermined spacing or different speeds.

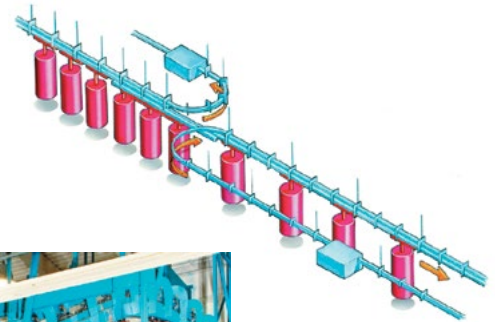

Elevation Changes

The conveyor can negotiate inclines, declines, and curves easily to suit production requirements, free up aisle space, and maximize use of available floor space.

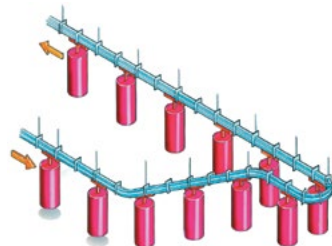



Carrier Indexing

Positive load control and varying chain speeds allow the intermittent indexing of carriers to accommodate different work-station requirements.

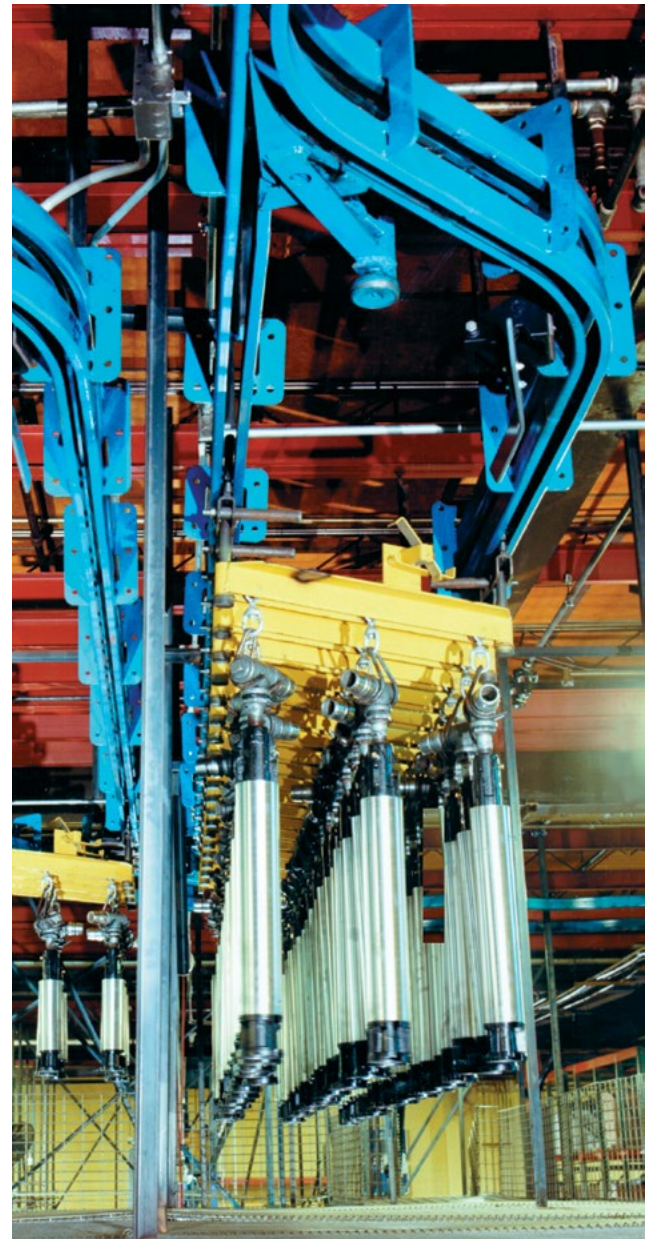
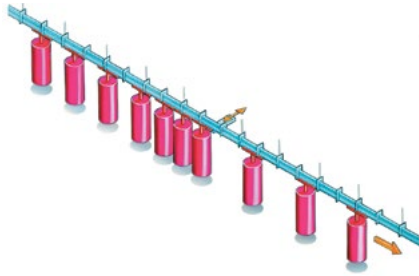

High Density Accumulation

Because of track and trolley design flexibility, long loads can be accumulated on a bias allowing very compact on-line storage.

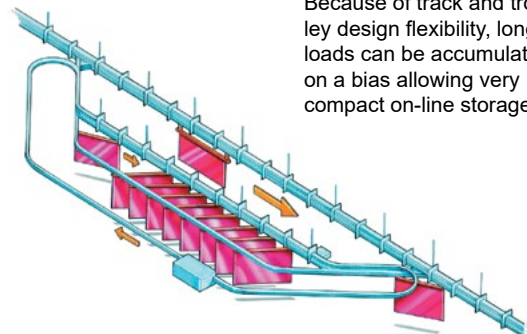

On-Line Storage and Segregation

When there is a need to hold work-in-process or in temporary storage, carriers can be switched from the main line to recirculating loops or to dedicated spurs for batched storage.

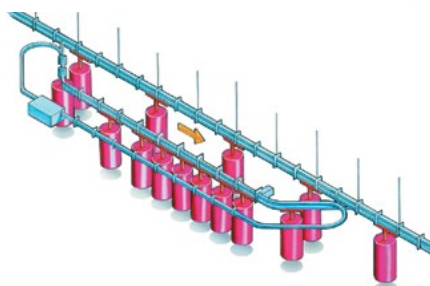

The patented **Wide Wing assembly** features a retractable dog assembly that improves carrier transfer from one conveyor to another. This exclusive design provides quick, smooth chain-to-chain transfers without the need for push across transfers or paddle wheels. The Wide Wing design also eliminates the need for quick drops and rises in the track, when a carrier enters or exits stop mechanism.

Wide Wing benefits include less complicated conveyor design and fabrication, smoother conveyor operation and reduced maintenance costs associated with fewer components.

The Wide Wing Concept: Transfers without pushers

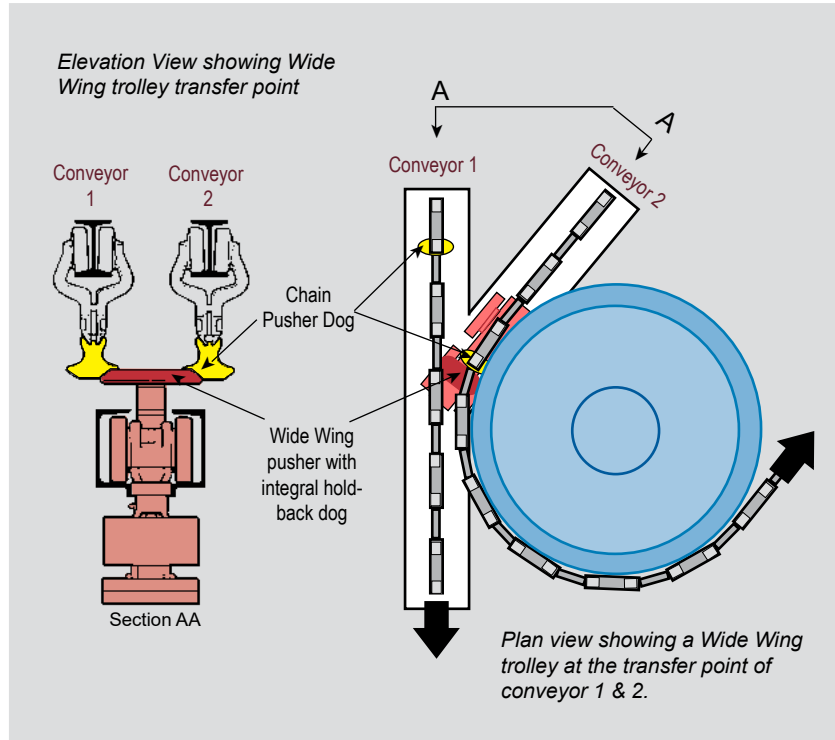

A load on Conveyor #2 is transferred to Conveyor #1 when the patented Wide Wing pusher on the Dog Magic Power & Free trolley is contacted by the chain dog on Conveyor #1.

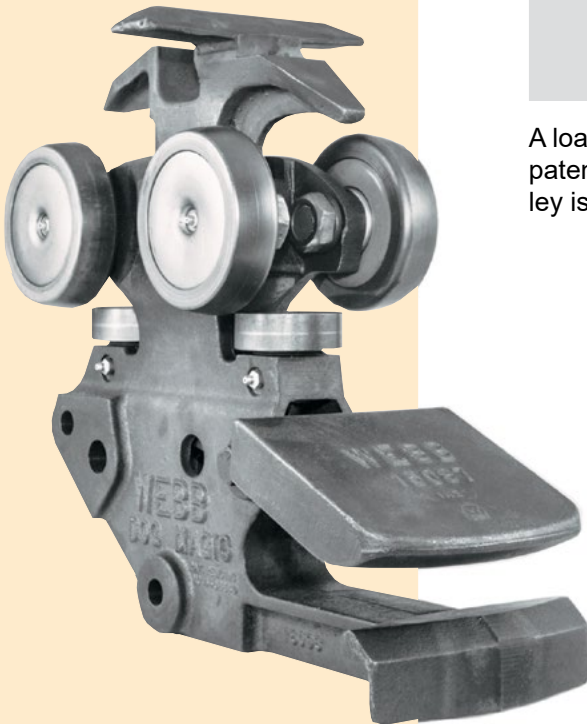

Overhead Wide Wing Accumulation Trolley

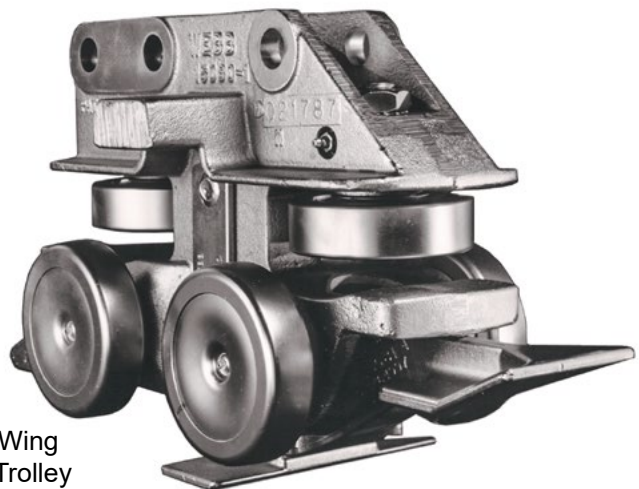

Inverted Wide Wing Accumulation Trolley

Rivetless Conveyor Chain

Quality materials and construction go into Webb rivetless chain. Drop forged from high strength Microloy™ steel our conveyor chain has an increased resistance to wear, abrasive action, and greater ability to withstand shock loads, providing long-lasting conveyor chain performance.

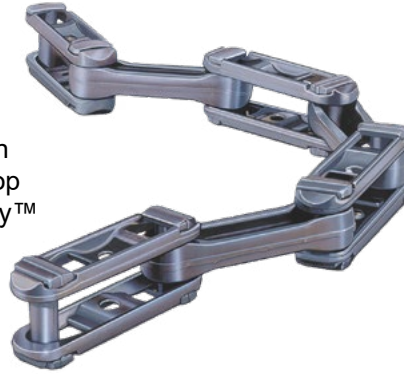

Stock Chain	X348	X458	X678
SI	X-75-13	X-100-16	X-150-22
Assembled Weight	2.25 lb/ft	3.10 lb/ft	6.5 lb/ft
SI	3.35 kg/m	4.63 kg/m	9.67 kg/m
Average Ultimate Strength	40,000 lb	68,000 lb	125,000 lb
SI	18,144 kg	30,845 kg	56,700 kg

LUBRIPIN™

One of the most significant changes to chain conveyors in the past decade, the LubiPin features concave edges with notches to enable oil to flow quickly down the pin – reaching the high-wear bearing surfaces fast. LubiPin increases chain longevity, reduces chain stretch, and results in a quieter operation for customers.



Made from high-strength microalloy steel, the durability and reliability are what separates our chain conveyor from all the rest. Our rivetless conveyor chain pins are precision forged and finished to provide the smoothest chain pin bearing surface in the industry.



LubriPin benefits include:

- Improved lubrication
- Increases longevity
- Quieter operation
- Less friction, causing less wear
- Reduces chain stretch and break-in time

Unibilt® Conveyor Chain

Heat-treated, high carbon steel components including stamped side links, drop-forged universal chain pins, and machined wheels enable our standard chain to excel in such harsh environments as bake ovens and spray booths. For applications that demand optimal performance with minimal operating noise, nylon wheel chain is also available.

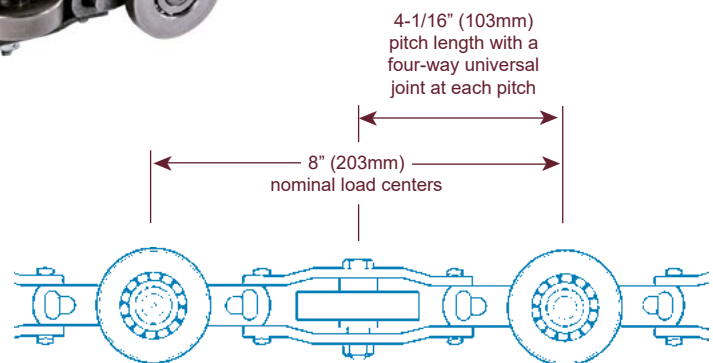
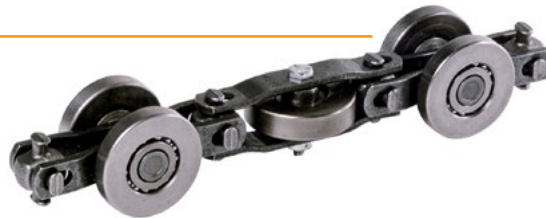

Uni/Uni Overhead Conveyor*Up to 500 lb (226kg) capacity**

Standard Horizontal Turn Radius - 24" (610mm)
 Standard Horizontal Turn Angles - 30°, 60°, & 90°
 Standard Vertical Curve Radius - 36" (914mm)
 Standard Vertical Curve Angle - 30°

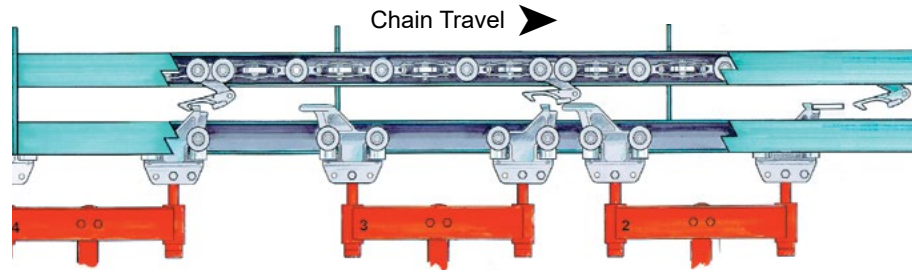
**3" Overhead Dog Magic Conveyor***Up to 1,500 lb (680kg) capacity**

Standard Horizontal Turn Radius - 18" (457mm)
 Standard Horizontal Turn Radius For Uni/3" - 24" (610mm)
 Standard Horizontal Turn Angles - 30°, 60°, & 90°
 Standard Vertical Curve Radius - 96" (2438mm)
 Standard Vertical Curve Angle - 30°

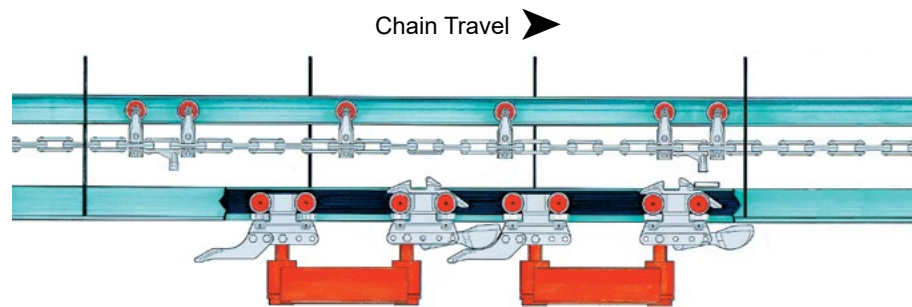
**4" Overhead Dog Magic Conveyor***Up to 2,500 lb (1140kg) capacity**

Standard Horizontal Turn Radius - 24" (610mm)
 Standard Horizontal Turn Angles - 30°, 60°, & 90°
 Standard Vertical Curve Radius - 144" (3657mm)
 Standard Vertical Curve Angle - 30°

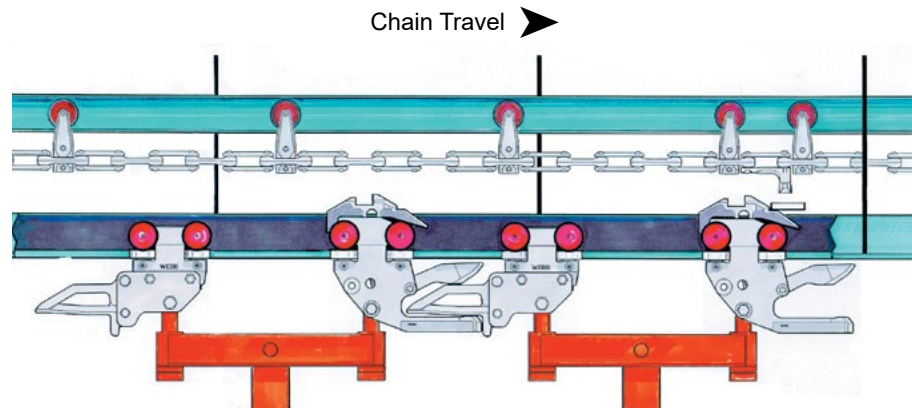
**6" Overhead Dog Magic Conveyor***Up to 8,000 lb (3600kg) capacity**

Standard Horizontal Turn Radius - 36" (914mm)
 Standard Horizontal Turn Angles - 30°, 60°, & 90°
 Standard Vertical Curve Radius - 240" (6096mm)
 Standard Vertical Curve Angle - 30°

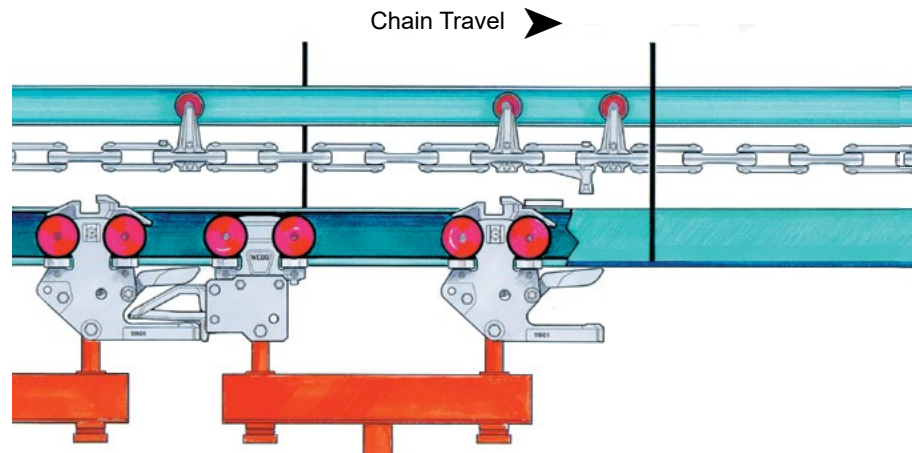

* Load capacity noted is for level systems only.
 For load capacity of non-level systems, please
 contact our Sales Engineer.

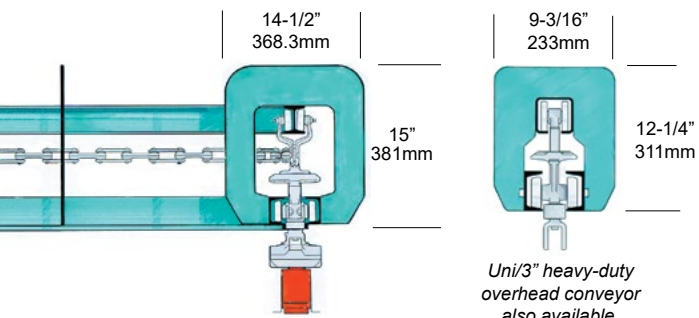
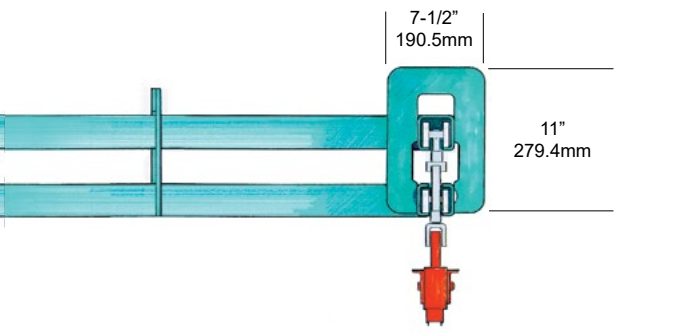

Uni/3" heavy-duty overhead conveyor also available.

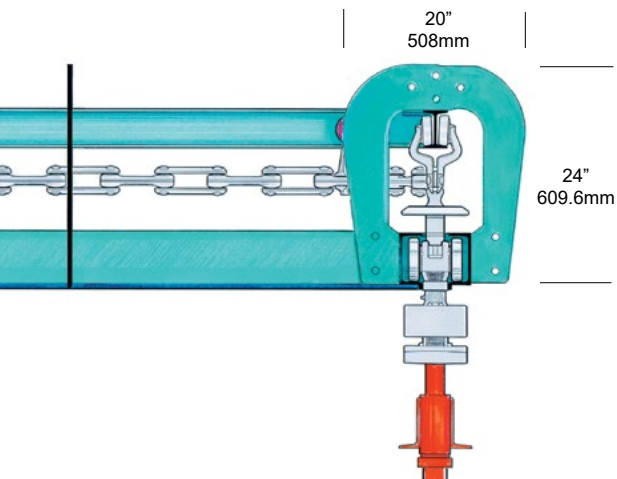
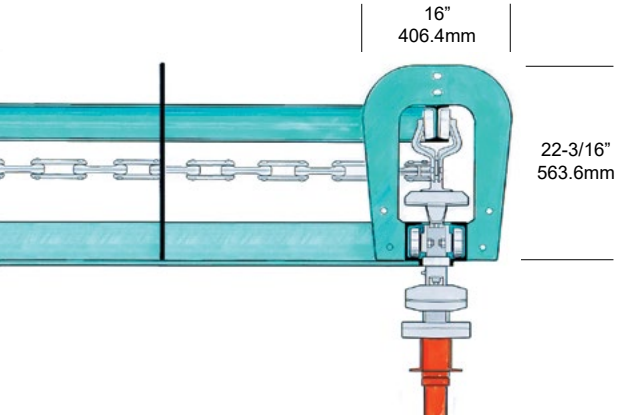

Optimum Use of Floor Space...Inverted Power & Free transports the product on a pedestal, therefore production line operations can be performed quickly and efficiently without obstruction. The system may be mounted on the floor, flush with the floor, or at building truss height to accommodate plant conditions.

3" Inverted Unibilt Conveyor

*Up to 1,500 lb (680kg) capacity**

Standard Horizontal Turn Radius - 24" (610mm)
 Standard Horizontal Turn Angles - 30°, 60°, & 90°
 Standard Vertical Curve Radius - 36" (914mm)
 Standard Vertical Curve Angle - 30°

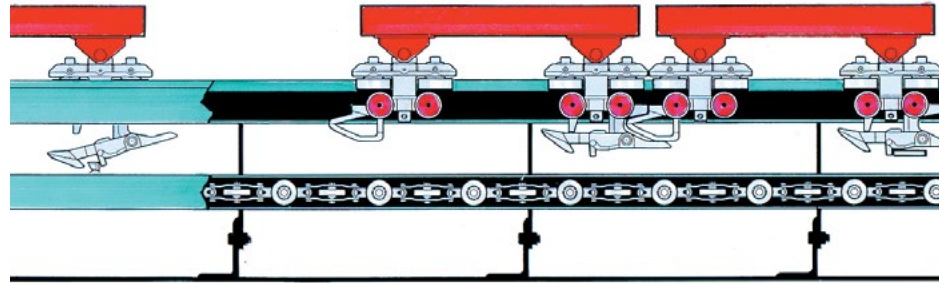

Chain Travel ➤

4" Inverted Dog Magic Conveyor

*Up to 2,500 lb (1140kg) capacity**

Standard Horizontal Turn Radius - 24" (610mm)
 Standard Horizontal Turn Angles - 30°, 60°, & 90°
 Standard Vertical Curve Radius - 144" (3657mm)
 Standard Vertical Curve Angle - 30°

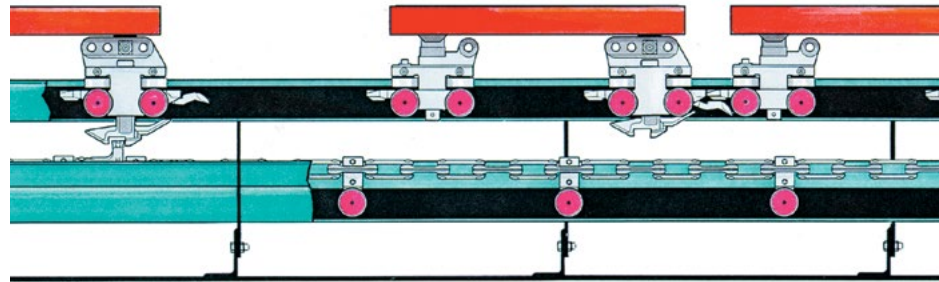

Chain Travel ➤

6" Inverted Dog Magic Conveyor

*Up to 8,000 lb (3600kg) capacity**

Standard Horizontal Turn Radius - 36" (914mm)
 Standard Horizontal Turn Angles - 30°, 60°, & 90°
 Standard Vertical Curve Radius - 240" (6096mm)
 Standard Vertical Curve Angle - 30°

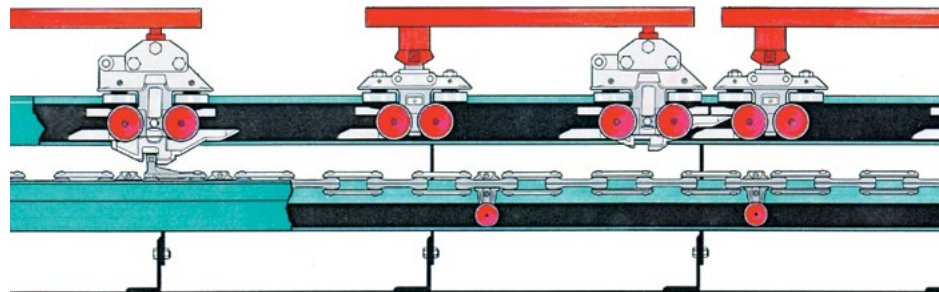

Chain Travel ➤

* Load capacity noted is for level systems only.
 For load capacity of non-level systems, please
 contact our Sales Engineer.

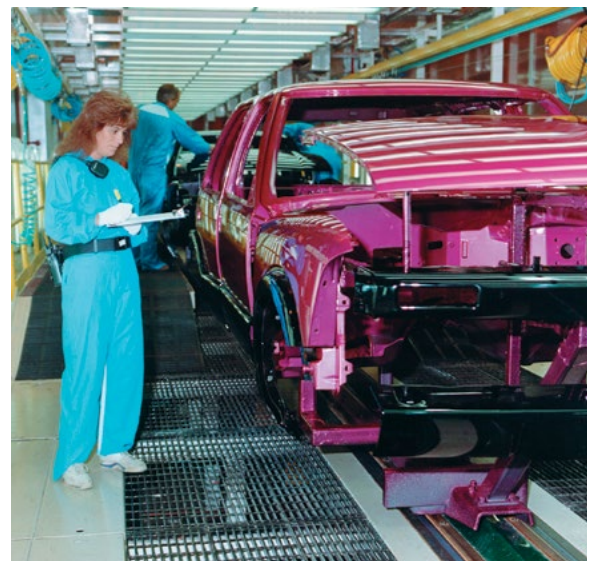
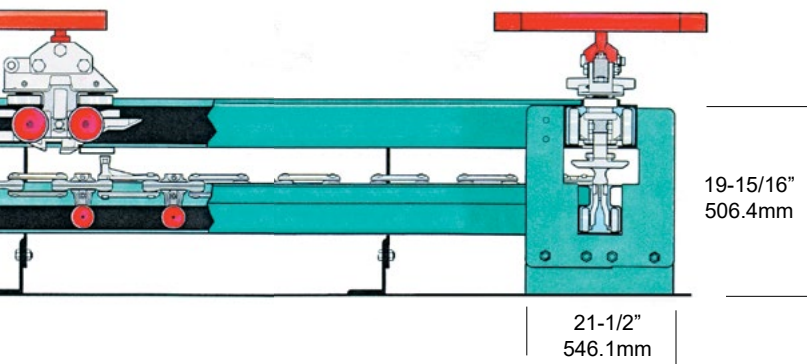
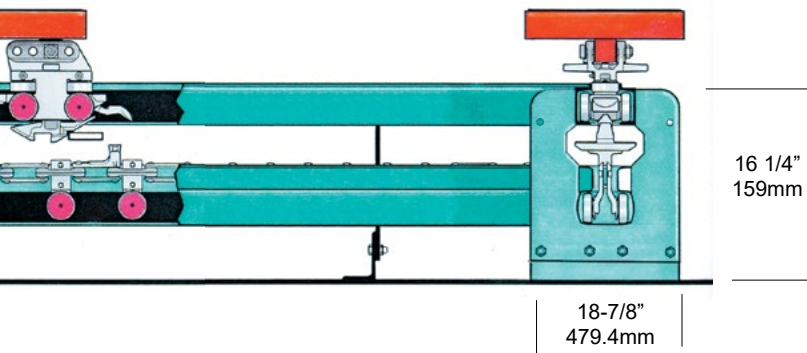
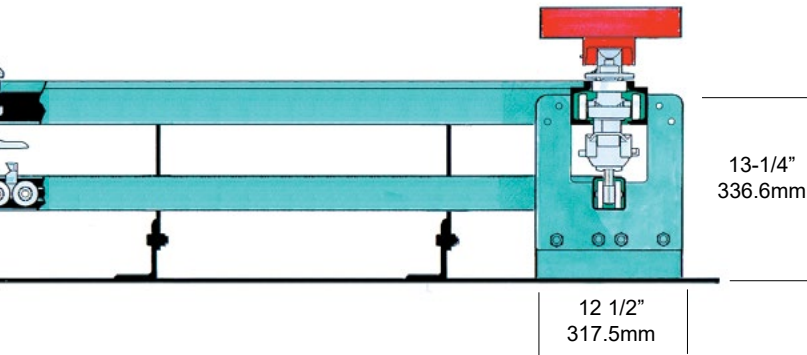

WIDE WING DOG MAGIC

Load Bar Arrangements

Load bar arrangements can consist of several varieties, depending on length of loads being carried and whether or not the carrier and load will be accumulated on horizontal curves. The simplest load bar arrangement uses a Power & Free trolley in the front and a rear load trolley with a cam attachment. The carrier is either hung from the load bar between the trolleys or from the trolleys themselves.

As load lengths increase, it is necessary to use a three or four trolley arrangement. Load bar lengths must be coordinated with the radius of horizontal and vertical curves. These considerations apply to both overhead and inverted conveyor systems.



2 Trolleys with Load Bar

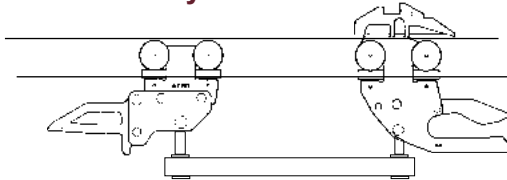

3 Trolleys with Load Bar & Tow Bar

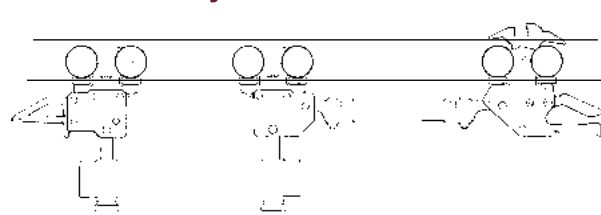

LOAD CAPACITIES

	Conveyor Type	Single Trolley		2 Trolley		3 Trolley	
		lb	kg	lb	kg	lb	kg
OVERHEAD	Uni/Uni	250	113	500	226	500	226
	Uni/3"	750	340	1500	680	1500	680
	3" Dog Magic	750	340	1500	680	1500	680
	4" Dog Magic	1250	570	2500	1140	2500	1140
INVERTED	6" Dog Magic	4000	1800	8000	3600	8000	3600
	Uni/3"	750	340	1500	680	1500	680
	4" Dog Magic	1250	570	2500	1140	2500	1140
	6" Dog Magic	4000	1800	8000	3600	8000	3600

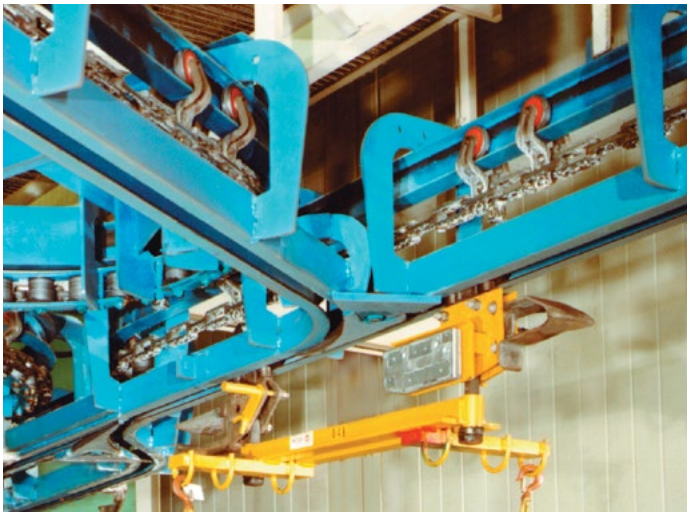

Switches

Track switches can be furnished in a variety of configurations. Diverging switches are referred to as unload switches where a single conveyor path is split into two paths.

Converging switches are referred to as load switches where two conveyor paths come together into one path.

A loading track switch does not require an air cylinder since the trolleys will rotate the tongue to the proper position required to pass the trolleys through the switch. In the switching process, there are two chains involved. Sometimes it is the same chain, sometimes the chain of a different conveyor. If it is a different conveyor, the speeds may be the same or different.



Trolley Stops / Anti Backup Devices

A trolley stop is an air operated device that places a blade in the path of a free trolley to stop the carrier. The blade causes the dog on the front trolley to retract, releasing the trolley from the power chain. The trolley is held in position at the stop by the retractable dog on the trolley and an anti-backup device which is mounted on the free track.

Subsequent carriers approaching a carrier in a stop are accumulated by the normal Power & Free action of one carrier banking against another. When the stop blade is removed, the retractable dog rises to be engaged by the next power chain pusher. Banked carriers proceed forward much the same as automobiles at a traffic light until the controls again move the stop blade into position which stops the next carrier.



Lift / Lower Stations

Lift/Lower Stations are a good alternative to vertical curves when elevation changes are extreme and floor space is limited. Lift/Lower Stations are suitable for use in both overhead and inverted conveyor configurations.

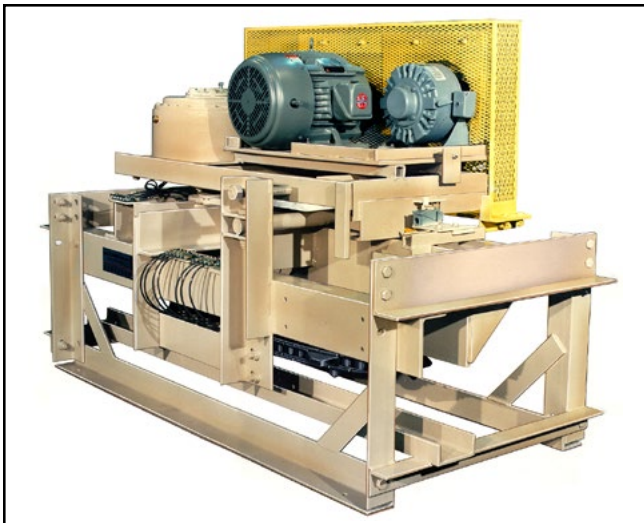

Caterpillar Drive Units

Our rotary “Caterpillar” drive design engages the conveyor power chain directly at its pins. This eliminates the need for special cams or springs required by conventional units and prevents the transfer of tension to load and guide wheel assemblies.

High efficiency reducers/gearmotors provide effective transmission of power from drive to conveyor. An automatic overload cutoff switch eliminates the need for shear pins.

Takeups

Takeups maintain proper chain tension by applying a constant force upon the conveyor power chain as it leaves the drive. This helps ensure smooth conveyor operation, and extends component life.

Takeups are available with a variety of adjustment methods including pneumatic, counterweight and spring operated.

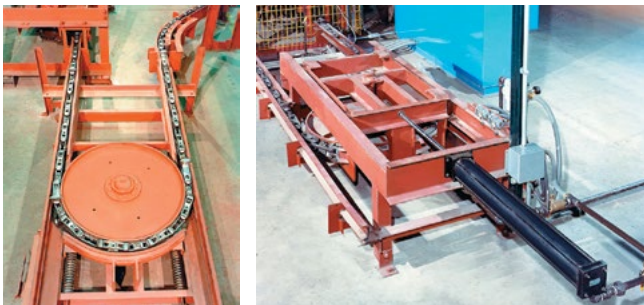

System Controls

A vast array of technology - including Programmable Logic Controllers (PLCs), Personal Computers (PC's), networked client server systems, and application specific software packages provide a comprehensive range of controls capabilities.

Sophisticated, yet user-friendly human/machine interface (HMI) terminals allow “real-time” management of entire material handling processes. By monitoring a selection of displays, operations personnel can efficiently oversee and evaluate system status, and make adjustments accordingly.

Inventory management, network communication between computer systems, automatic load identification, and individual load tracking controls can also be incorporated into your system.

Extreme Conditions

Whether materials need to be conveyed through a bake oven or paint system, our products are engineered to provide consistent performance even in extreme conditions.



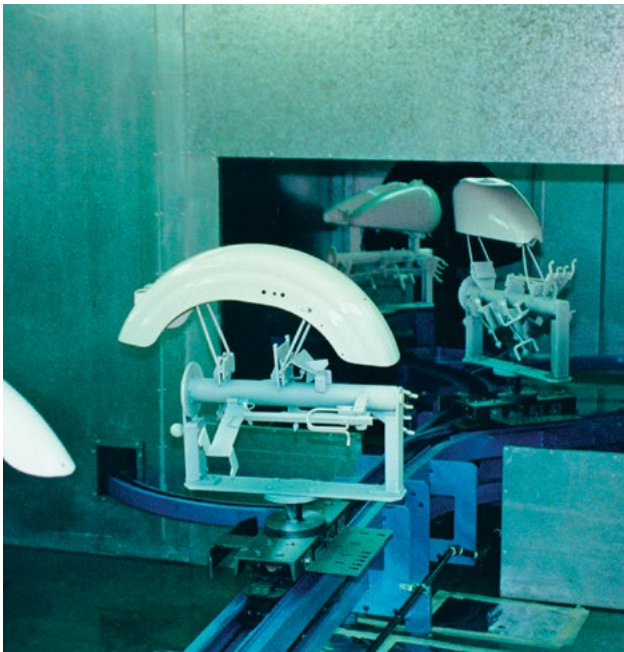

Support Services

In order for your Power & Free system to achieve its maximum level of productivity and efficiency, you must feel completely comfortable with all aspects of its operation.

Contact your local Daifuku Sales Representative for more information on these and other services.

Installation and Commissioning

To ensure the mechanical, electrical, and structural integrity of your new system, all equipment is subjected to rigorous testing *prior* to commissioning.

Training and Documentation

Comprehensive hands-on and classroom training programs can be designed to meet your specific needs. Detailed operation/maintenance manuals and maintenance technician training provide full-time, on-site support. And our multi-disciplined engineering staff is available to provide professional expertise and support.

Maintenance and Parts

A full range of maintenance and service programs are also available to provide additional support if desired including: preventative maintenance programs; conveyor system evaluation services; and detailed conveyor operation analysis studies.

Contact our dedicated Parts and Service team for fast, efficient replacement parts and technical assistance: 1-248-553-1232

Please Note: No sale of Power & Free components shall constitute the granting (either expressly, by implication, estoppel or otherwise) of any license under any existing or pending patents of Daifuku or its subsidiaries.

In this catalog, information of a technical nature has been included to aid the engineer in preparing preliminary systems drawings. The dimensions and data given here are subject to change without notice and should not be used for construction purposes. For detailed information, please consult your local Daifuku sales engineer or the factory. Features of the Dog Magic conveyor system are patented in the U.S. and principal foreign countries.

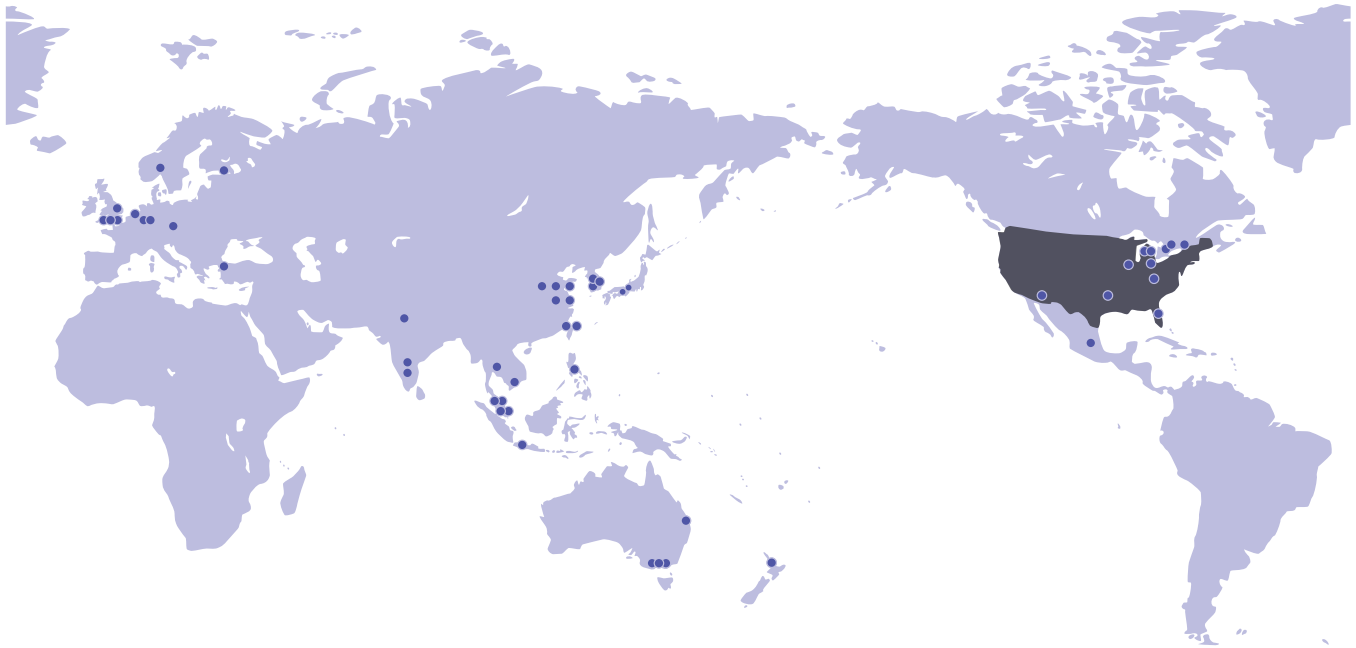

Manufacturing Facilities

Carlisle Plant

P.O. Box 400,
Carlisle, SC 29031 USA
Tel: 1-864-427-8421
Fax: 1-864-427-8425

Reynoldsburg Plant

6700 Tussing Road
Reynoldsburg, OH 43068
Tel: 1-614-863-1888

Hamilton, Ontario Plant

1647 Burlington Street, East
POB 3428 Station "C", Hamilton,
Ontario, L8H 3L2 CANADA
Tel: 1-905-547-0411
Fax: 1-905-549-3798

DAIFUKU

30100 Cabot Drive, Novi, MI 48377 USA
Phone: (248) 553-1232 Fax: (248) 553-1253
E-mail: dacproductsales@daifukuamerica.com
www.Daifuku.com