

ENCLOSED TRACK CONVEYORS

UNIBILT®

Power & Free CONVEYORS

OVERHEAD and INVERTED

DAIFUKU

Daifuku introduced the first power & free conveyor in 1939 to address the unique concerns of automotive operations. But with each successive installation, the tremendous potential for widespread application became more and more clear.

In 1964, we established our Unibilt product line to meet increasing demand from the light to medium duty conveyor market. Unibilt's unique, enclosed track design represented a marked improvement in operating cleanliness. And, our long-term prominence as a manufacturer of customized material handling systems allowed us to adapt the latest developments for use in a standardized line of equipment.

Each breakthrough—from the introduction of computerized controls to the incorporation of modular components—has provided another step toward the high-tech capabilities of today's Unibilt enclosed track power and free conveyors. Yet with all that has changed, the core Unibilt principle remains rock solid: *Clean running material handling systems that combine the advanced features of custom designed technology with long-term reliability of proven, standardized equipment.*

Contents

Why Power & Free?.....	2	Pusher Dog Assemblies	15
Overhead Systems	4	Switches	16
Inverted Systems	6	Stop Assemblies	16
Trolleys	8	Anti-Backup Devices	17
Trolley/Load Attachment Configurations	10	Limit Switch Actuators	17
Carriers	11	Caterpillar Drive Units.....	18
Track.....	12	Chain Take-Ups	19
Turns	12	Lift Stations.....	20
Universal Link Chain.....	14	Controls	20

UNIBILT®

ENCLOSED TRACK CONVEYORS

Designed and manufactured for quality, reliability, and low cost performance by the Daifuku Automotive America Corporation.

Most conveyors are made to look like a Unibilt conveyor, but they're just not designed to give the reliable performance of a Unibilt conveyor.

TRACK

Unibilt Track is precision roll formed from patented microalloy steel— a specially formulated high strength carbon steel that is harder, stronger and designed to last longer— an exclusive feature of Unibilt track.

Horizontal Turns and Vertical Curves- 24" and 36" radius horizontal turns and 24" radius vertical curves are heat treated on the wear surface for added anti-wear qualities.

CHAIN

Side Links- Unibilt chain side links are heat treated for longer life.

Wheels- Unibilt wheel races and ball bearings are manufactured from alloy steels, including high-carbon and high-chromium, 52100 alloy steel. These superior "through-hardened" grades of steel were selected for the superior depth of hardness attainable, superior wear resistance, and improved corrosion resistance.

Symmetrical Chain Pins- Unibilt symmetrical chain pins are precision drop-forged from carbon alloy steel, not stamped.

DRIVES

Unibilt 750# drive units feature a compact, high-efficiency inverter duty motor/reducer combination that sends more power directly to the drive. This configuration immediately reduces noise and maintenance, while improving overload cut-off accuracy and durability.

The electrical automatic cutoff device is factory adjusted to stop the motor/reducer automatically when an overload condition occurs.

Please Note: This catalog is designed to illustrate the various Unibilt components and their applications in a conveyor system. Although self design and installation of a Unibilt system are possible, we strongly recommend working with Unibilt personnel to achieve the correct application of Unibilt products. You should be aware that environmental and many other conditions may vary with each installation. The Daifuku Automotive America Corporation does not warrant that adherence to any guidelines or suggestions set forth in this brochure will necessarily result in proper selection, manufacture, installation and maintenance of conveyor equipment and/or a conveyor system. Unless there are specific written specifications or recommendations and pursuant to a written contractual commitment from it, the Daifuku Automotive America Corporation hereby disclaims all responsibility for any equipment and/or system malfunction, any violations of law, property damage, personal injury or any other damages resulting from equipment and/or system selection, design, installation, maintenance, or operation carried out by a contractor, user or any other person.

No purchases of Unibilt components shall constitute the granting (either expressly, by implication, estoppel or otherwise) of any license under any existing or pending patents of the Daifuku Automotive America Corporation.

Why...

Power & Free?

Ideal for handling capacities from 25 lb (11kg) up to 3,000 lb (1361 kg) *using a four trolley load bar configuration.*

Power & free conveyors provide direct, positive control of each load in the system making them ideally suited to industrial applications that demand maximum versatility, productivity, and efficiency.

This high level of control is due to the dual track configuration of power & free systems. The main (or “power”) track is a chain-driven conveyor that moves carriers through the system. The second (or “free”) track allows individual carriers to be disengaged from the main track and rerouted onto an adjacent spur line.

The Power & Free design permits an extensive range of operations, including...

On-Line Accumulation

On-line accumulation allows both main and spur lines to be used for in-process (live) storage. This is particularly important in applications where the rate of production varies between workstations. Accumulated carriers can be returned to the production line for completion. The accumulation process consists of three basic steps:

1. Stop blade moves into position between carriers (1) and (2). Pusher dog moving carrier (2) encounters stop blade and pivots up, releasing carrier from power chain.

2. Pusher dog moving carrier (3) encounters rear trolley of carrier (2), releasing carrier from power chain.

3. The sequence is repeated for all trailing carriers (4, 5, etc.) until the stop is released, allowing the front trolley of the lead carrier to be picked up by a pusher dog and moved along the free track.

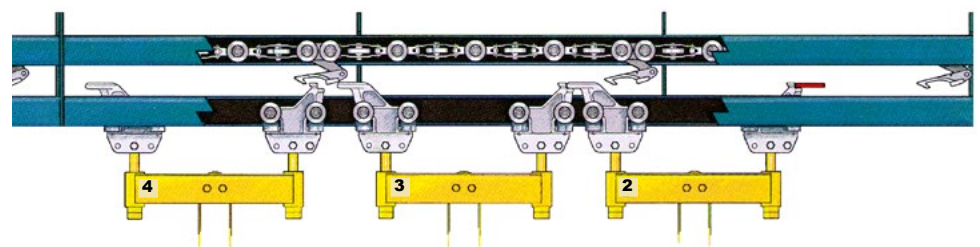
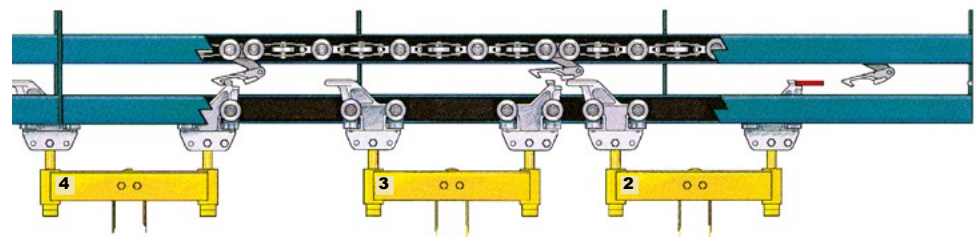
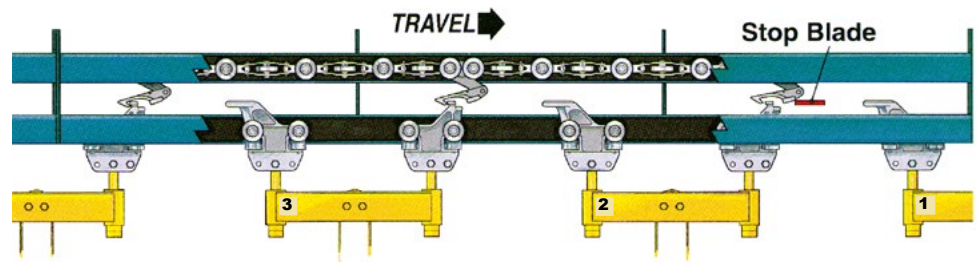

Noise Reduction Components

In addition to the standard “all-steel” parts, special noise reduction components are also available in non-metallic material that significantly reduce operating noise. These products, including trolley wheels, chain wheels, pusher dogs, and anti-backups - reinforce the system’s already clean, quiet performance by incorporating non-metallic parts at key points of contact (i.e., wheels, pusher dogs, anti-backup blades, etc.).

Diagonal Banking

This feature provides the benefits of live storage in a space-saving format. Diagonal banking uses two or more parallel lines — one, the complete set of power and free tracks; the others, the free track only. A mechanically actuated switch alternately opens and closes, directing the lead trolley onto the power line and the rear trolley onto the free lines. Banked carriers are positioned on an angle, providing additional storage capabilities in less space. This allows ovens, cooling lines, and staging areas to be compressed into compact areas, significantly reducing the total amount of floor space required for overall system operations.

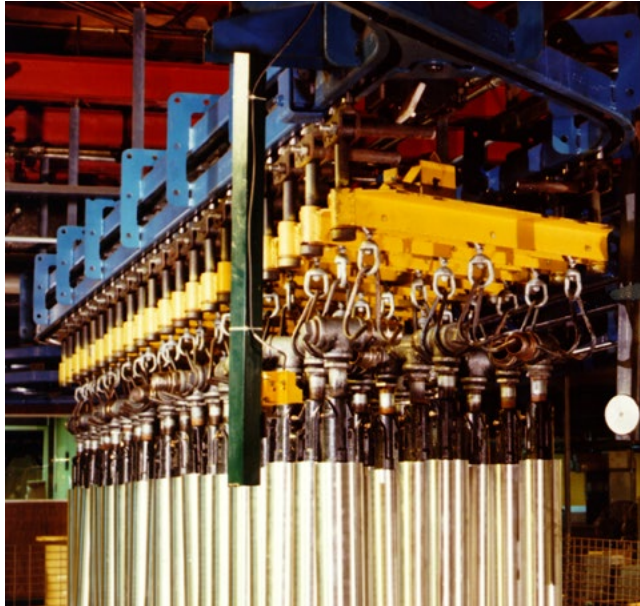

Switching

Unibilt switches allow the smooth transfer of carriers between the main line and various spur lines (i.e., finishing/drying lines, workstations, storage loops, or adjacent conveyor lines).

Variable Chain Speed

The wide variety of power & free operations (i.e., assembly, finishing, transportation from storage) requires different rates of travel to ensure safe and efficient handling. For example, carriers that move parts from storage to the assembly line can be transported at a greater speed than those involved in the finishing process. Variations in speed are accomplished by using separate drive units to power specific sections of the system.

An added benefit of this approach is that limited amounts of chain are exposed to heat, chemicals, and other contaminants.

Computer Interfacing

Webb’s computerized controls increase efficiency and productivity even further by integrating diverse operations into a single, unified system.

Among the many features available are a full range of optional carrier identification systems that utilize coded carriers to allow precise tracking and management of individual loads.

Additional Benefits...

Close tolerance forgings increase component life span, providing extended performance.

Unibilt’s modular designs enhance flexibility even further. The easily installed components let your system grow along with your needs – allowing convenient, controlled expansion while optimizing your initial investment. And with virtually unlimited possibilities for system configuration, you get the best possible use of available floor space.

Changes in elevation are accomplished smoothly and efficiently. Standardized inclines and declines help keep aisles clear; allow floor-to-floor transfer; improve utilization of overhead space; and enable the ergonomic design of workstations.

Unibilt power & free conveyors are available in both overhead and inverted configurations which can be used individually or combined to meet your specific requirements.

From Simple to Complex...

Overhead Power & Free

Overhead power & free configurations are the right choice for use in both simple and complex production, assembly, and finishing operations that demand a continuous supply of materials at each workstation.

Our unique, enclosed track design helps keep dirt and grease off of the product. High chain speeds provide continuous, rapid movement of materials between operations. The resulting increase in work flow heightens the efficiency and cost-effectiveness of the system.

Because the conveyor system design is flexible, it can negotiate inclines, declines, turns, and interface with virtually any type of automation or process equipment. And, since product movement takes place overhead, floor space can be used to its best possible advantage.

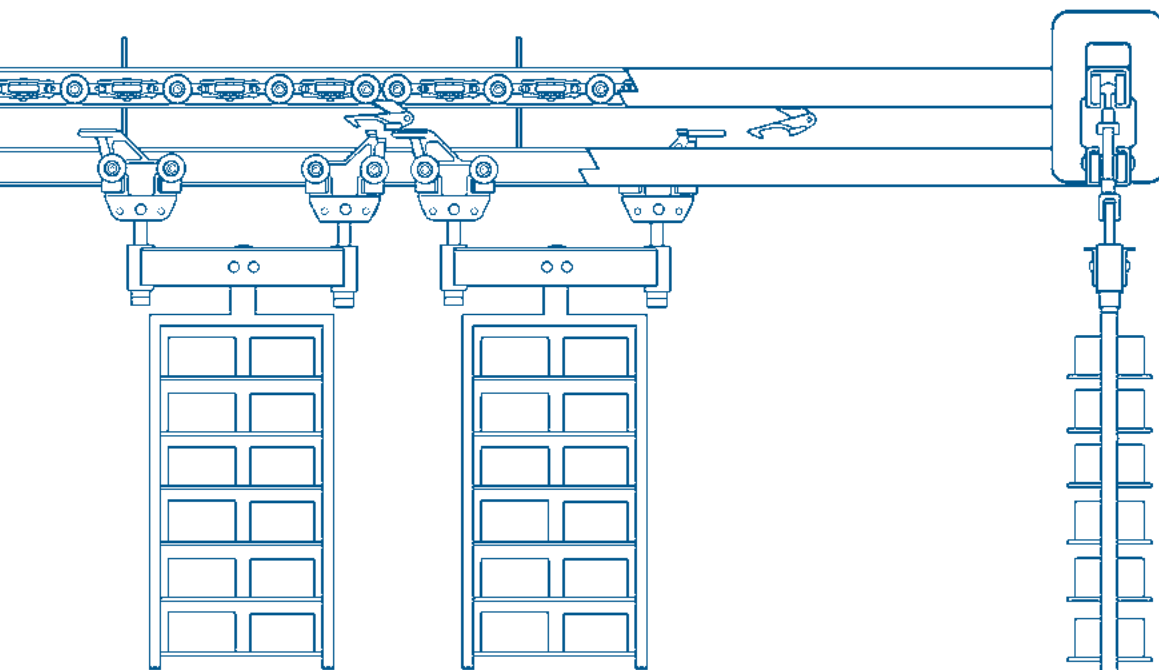

Innovative Ideas...





Unibilt provides solutions in a variety of material handling applications.

Above left, stripped airline carts travel through a sanitizing washer before routing to the repacking area.

Above right, electronic component manufacturer uses Unibilt power & free to transport parts to assembly stations.

Left, door assemblies in a banking mode waiting for further instructions in an automotive manufacturing facility.

Versatility...

Inverted Power & Free

Unibilt's inverted power & free configurations provide tremendous versatility, incorporating the benefits of both power & free *and* standard floor conveyors. In fact, our standardized components are specifically designed to meet the requirements of above floor, in-floor, and elevated (overhead inverted) systems.

The inverted approach greatly enhances the already clean operation of our enclosed track design, virtually eliminating contamination by falling debris. Plus, by locating all support and conveyance hardware beneath the product, inverted systems offer virtually 360° product accessibility, providing the opportunity for a multitude of in-process operations to be performed.

An additional benefit is the savings generated by the elimination of expensive transfer equipment used with standard floor conveyors.

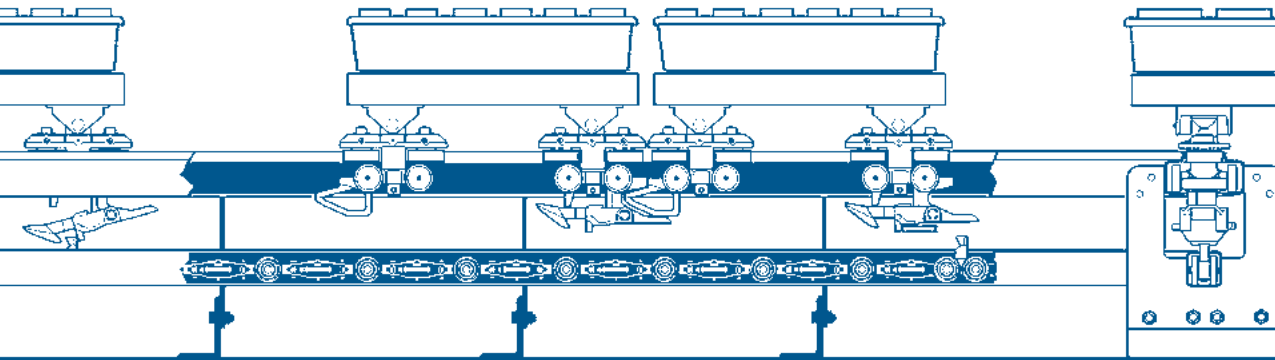

Custom Engineering...





Unibilt provides a variety of inverted system solutions.

Top right, caskets advance through the wash process prior to painting.

Bottom right, an inverted power & free conveyor accumulates range tops at a manual workstation.

Top left, motorcycle fenders move to storage after inspection.

Bottom left, automotive part manufacturer uses an inverted power and free conveyor to carry facia panels through finishing operations.

Unibilt Trolleys

*Smooth, dependable
trolley operation...*

An essential element of the power & free concept.

That's why Unibilt trolleys are designed and manufactured to provide top quality service.

Generally, power & free carrier assemblies are mounted on two trolleys (front and rear) that run in the free track. Positive load control -the heart of efficient power & free operation-is made possible largely by the distinctive features of these trolleys. In addition, an intermediate trolley is available for situations involving long loads.

All three types utilize the same basic design, with each trolley body formed from a single-piece casting to provide maximum durability. Wheels are available in steel (standard) and quiet running non-metallic (optional) models to suit the widest possible range of applications. Both wheel styles feature a full complement bearing design with hardened races for extended service life.

In addition, front trolleys feature a hardened head that allows the trolley/carrier assembly to be engaged and pulled along the free track by a pusher dog attached to the power chain. Rear trolleys, on the other hand, are equipped with a tail that enables disengagement. Front and rear guide rollers offer enhanced load control and lateral stability.

Unibilt overhead and inverted trolleys are available in standard and heavy-duty models, with maximum load capacities of up to 750 lb per single trolley.

UNI/UNI

Single trolley
load capacity
250 lb (113 kg)



Uni/Uni Front Trolley

UNI/3"

Single trolley
load capacity
750 lb (340 kg)



Uni/3" Front Trolley

3" INVERTED

Single trolley
load capacity
750 lb (340 kg)



3" Inverted Dog Magic Trolley



Uni/Uni Rear Trolley



Uni/Uni Intermediate Trolley



Uni/Uni Combination Trolley



Uni/3" Rear Trolley



Uni/3" Intermediate Trolley



Uni/3" Combination Trolley

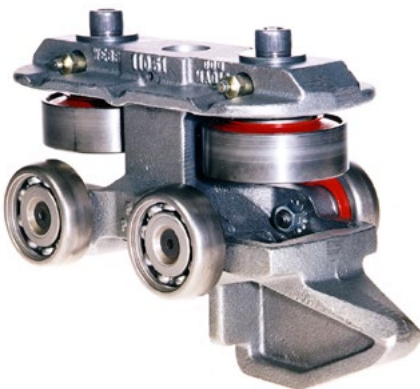

3" Inverted Rear Trolley

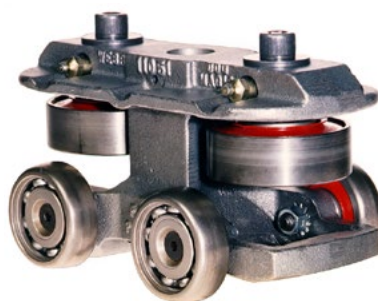

3" Inverted Intermediate Trolley



Uni/3" Reversing Trolley

Trolley/Load Bar Configurations

Four basic trolley/load attachment configurations are used in the majority of power & free operations. Each can be employed in both overhead and inverted applications.

Overhead

Single Trolley: A carrier assembly is suspended directly from the trolley's load attachment bracket. In order to maintain positive load control, the single trolley features both the hardened front contact bumper and rear cam tail. Suitable for use in basic finishing or material movement applications for loads up to 250 lb.

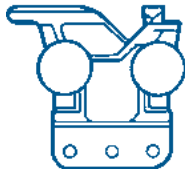

Two Trolleys: This set-up utilizes a load bar (overhead) or platform (inverted) to disperse the weight of the product evenly between the front and rear trolleys. It can be used in a diverse range of applications with load weights up to 1500 lb, making it the most common trolley configuration.

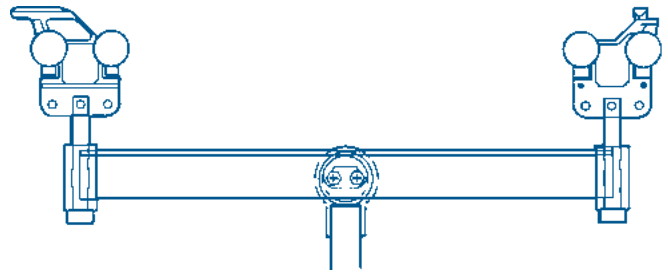

Three Trolleys: The basic two-trolley arrangement (with load bar) is fitted with a non-weight bearing front extension to accommodate longer loads for use in diagonal banking. Appropriate for use with weights up to 1500 lb.

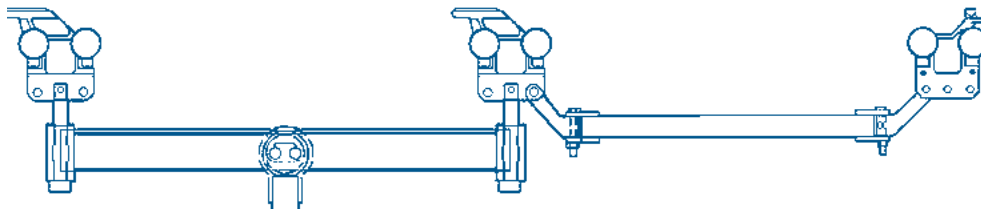

Four Trolleys: This is essentially a double two-trolley configuration, with two small load bars linked to a long, weight bearing load bar. By positioning the second set of trolleys opposite to the first set, the assembly is able to reverse directions. Designed for use with vehicle frame side members and other elongated products weighing up to 3000 lb.

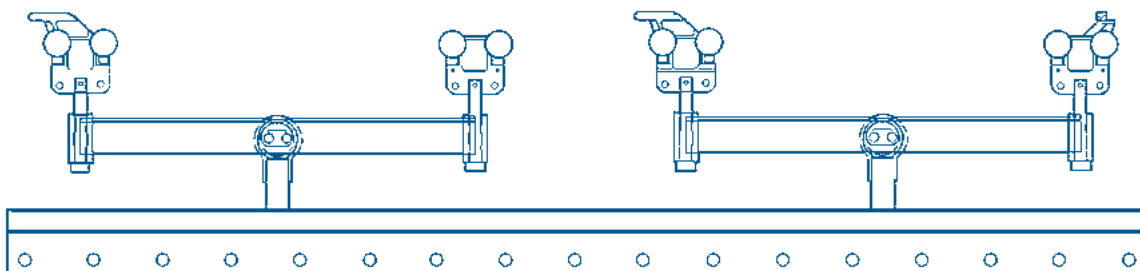

Inverted

Two Trolley: The inverted design utilizes a platform to evenly distribute the load weight between the front and rear trolleys.

Three Trolleys: An inverted two trolley arrangement is fitted with a front extension to accommodate long loads.

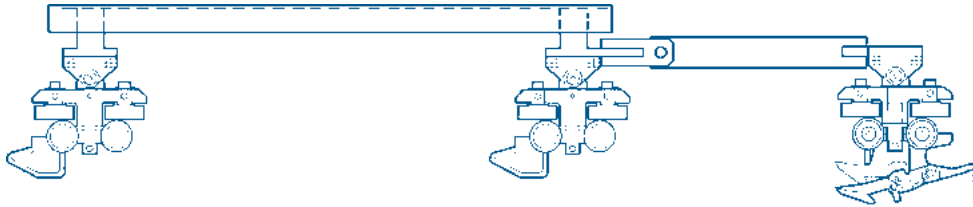
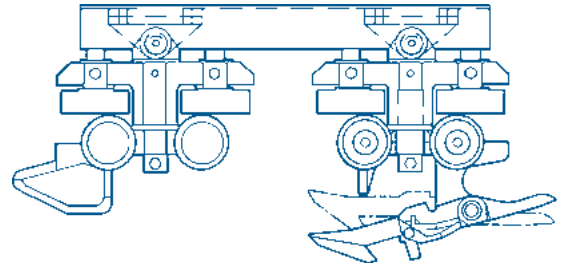

Carriers

Custom designed carriers provide maximum levels of efficiency and productivity.

Your local Unibilt Sales Engineer can assist in the design of special carriers to meet your needs.



Track

Standard Unibilt Power & Free track - Uni/Uni is constructed of roll-formed microalloy steel.

This special composite offers up to 26% greater yield strength than carbon steel - plus superior wear/corrosion resistance and load stability over long spans. In addition, the roll-form process results in a more uniform track cross-section, allowing stronger welds at joints.

For applications that require even greater corrosion resistance, Unibilt track is also available in roll-formed 300 Series stainless steel.

Free Track — *Standard duty free track* is constructed of roll formed half sections or 3" structural channels, leaving the top and bottom open to allow smooth travel of trolley/carrier assemblies.

Heavy-duty free track features a 3" channel to accommodate heavy-duty Unibilt trolleys. **Heavy-Duty Power & Free track - Uni/3"** is constructed of microalloy and 3" structural steel channels.

Unibilt overhead power & free track components are available with end yoke construction upon request.

Turns

Horizontal turns - A minimum of 24" radius turns are used on our systems with bends ranging from 15 to 180 degrees.

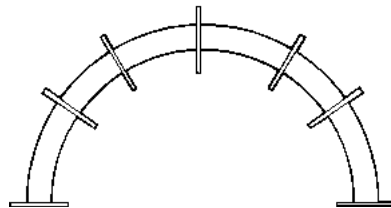

Vertical curves - have a minimum of 36" radius and a maximum 45 degree of incline & decline. The factory should be consulted for inclines or declines requiring an angle greater than 45°.

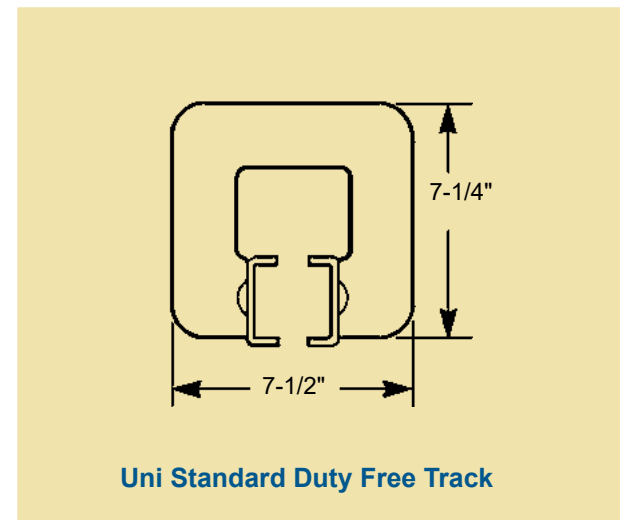
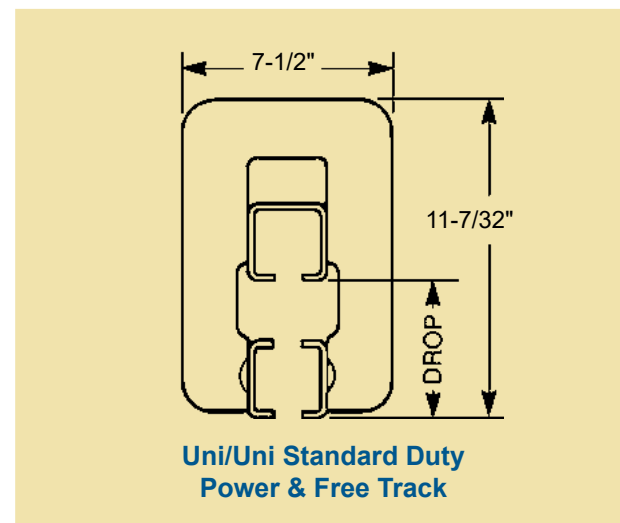
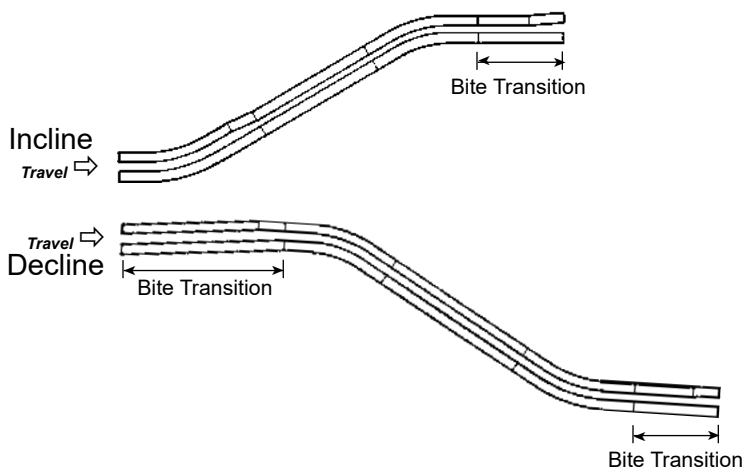

Microalloy Steel

- Lighter weight makes it easier to handle and imposes less load on the conveyor hangers and the building structure.
- This special alloy steel has greater abrasion resistance and better load-carrying characteristics than plain carbon steel, assuring longer life under most service conditions.
- Track can be welded using low hydrogen rod or wire and can be saw-cut in the field without special tools.

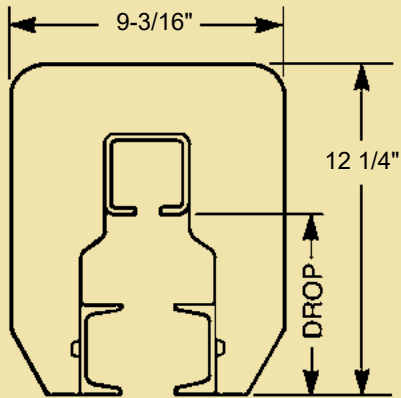

Uni/3" Heavy Duty Power & Free Track

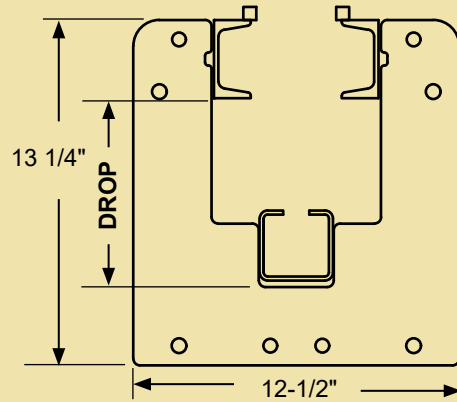

Inverted Heavy Duty Power & Free Lug Channel

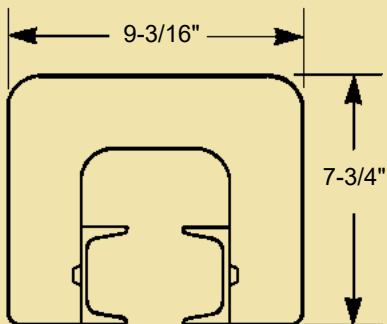

Heavy Duty 3" Free Track

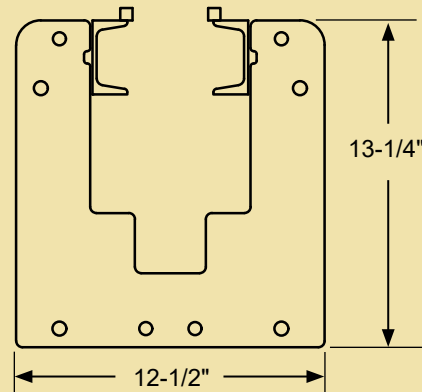

Inverted Lug Channel Free Track

Flexibility...

Universal Link Chain

Unibilt chain employs alternating vertical (load carrying) and horizontal (lateral guide) wheels with a symmetrical pin located at each pitch. This provides maximum flexibility in all directions, helping to reduce friction and promote long life. The use of true "U-joints" also allows easy chain assembly/disassembly.

Heat-treated, high carbon steel components including stamped side links, drop-forged symmetrical chain pins, and machined wheels enable our *standard* chain to excel in such harsh environments as bake ovens and spray booths. And, for applications that demand optimal performance with minimal operating noise, nylon wheel chain is also available. Plus, all load and guide wheels feature a full complement of ball bearings manufactured from alloy steels, including high-carbon 52100 alloy steel and hardened races for years of dependable service.

Nylon Wheel Chain

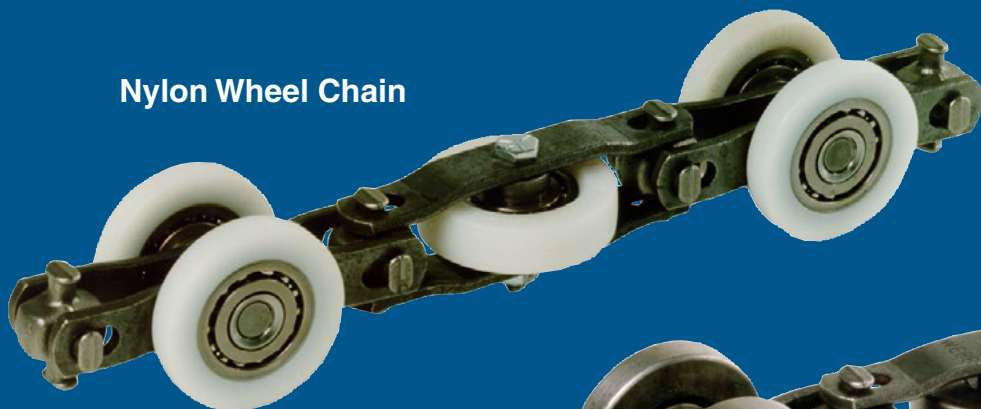

Standard Steel Wheel Chain



Universal Heavy-duty Chain with symmetrical chain pin is designed to provide maximum flexibility in all directions with a true universal joint at every pitch.

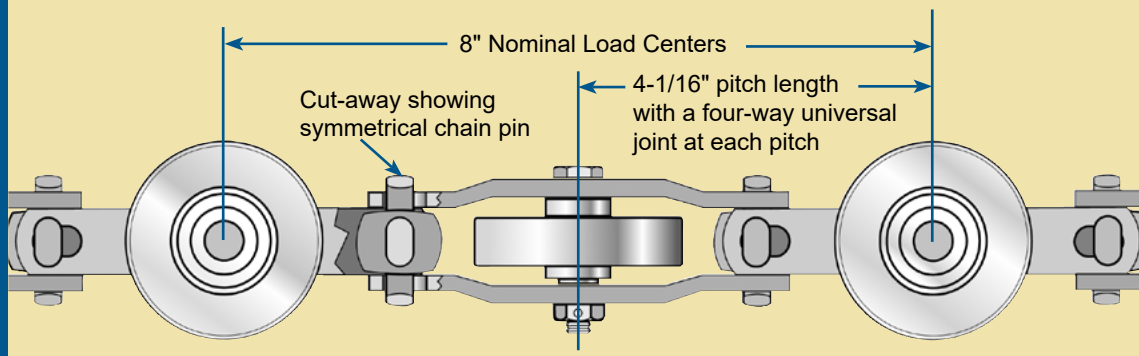

Pusher Dog Assemblies

Our exclusive pusher dog assembly offers several advantages over conventional “dogs” – including high-quality steel construction, hardened for added durability.

In addition, specially designed mounting pins eliminate the need for welded connections between the dog and wheel assembly. This minimizes maintenance time by allowing quick, easy replacement of the dog *without* breaking down the chain and removing the entire assembly.

And, like our chain and trolleys, Unibilt pusher dog assemblies are available with standard steel *or* optional non-metallic material - designed specifically for applications that demand reduced noise levels. All Unibilt pusher dogs feature a full complement of ball bearings and hardened races for extended service life.

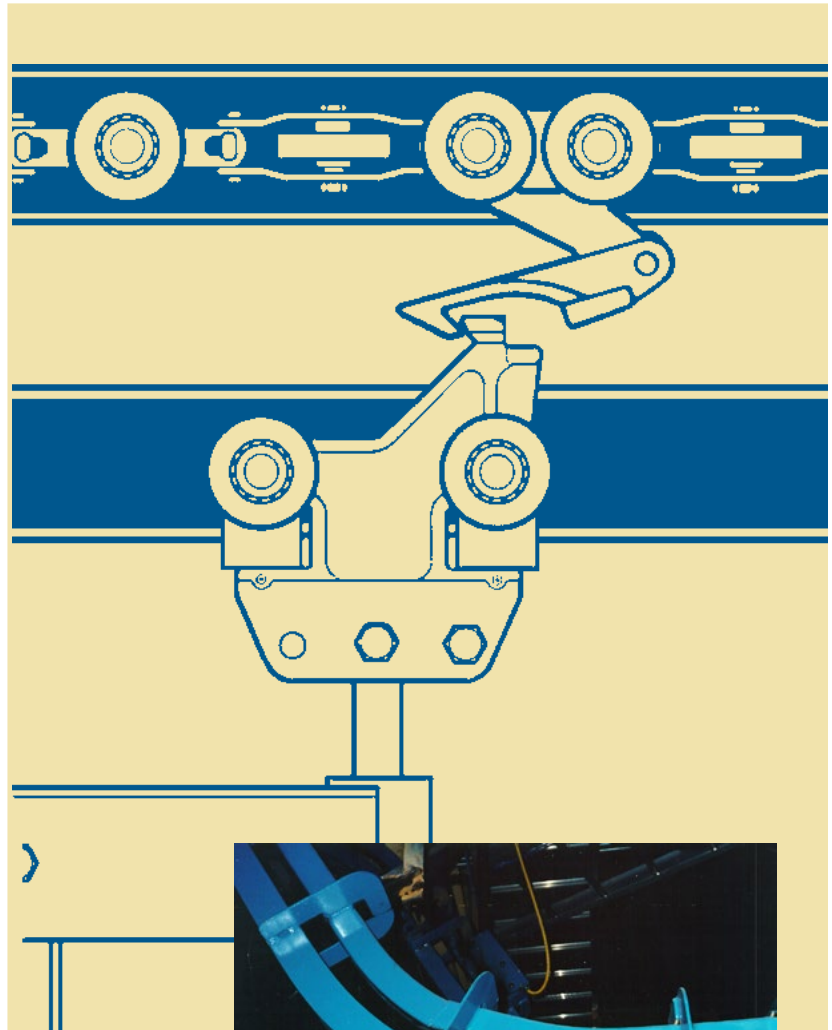

*Durable,
easy maintenance...*



Standard steel Pusher Dog with steel wheels



Non-metallic Pusher Dog with nylon wheels

Switches

Unibilt systems incorporate two basic types of switches:

- **Unload switches** route trolley/carrier assemblies off of the main power & free line to a spur line, workstation, lift station, or storage loop.
- **Load switches** are used to return assemblies to the main line as needed.

Switches are available in both manual (pull cord) and power models. Among the many options included are air cylinder and spring actuated designs that can be triggered automatically by specially coded carriers.

Stop Assemblies

A stop is a device used to disengage the pusher dog from the trolley assembly, halting forward movement of the carrier to allow performance of an on-line operation or to accumulate carriers. Once the operation is completed, the stop is released, enabling a trailing pusher dog to engage the trolley assembly for continued movement.

Unibilt power & free stop assemblies consist primarily of a mounting frame, a retractable stop blade, and an operating mechanism (manually, electrically, or pneumatically powered) that inserts and retracts the stop blade from the path of the pusher dog. Standard components are manufactured from high-carbon steel and stop blades are hardened for added durability.

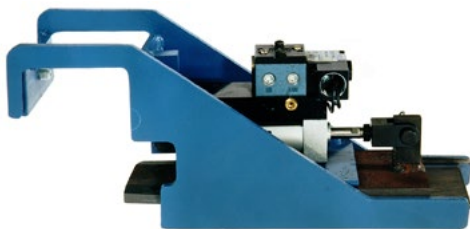

UNI/3" Overhead Conveyor standard stop assembly

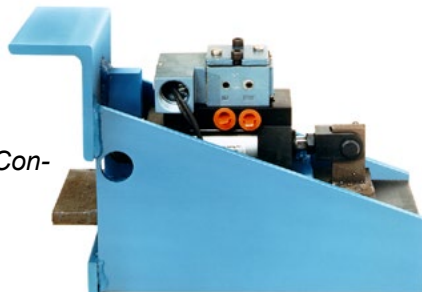

Uni/Uni Overhead Conveyor standard stop assembly

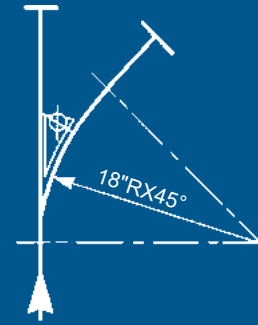

RH Unload Switch

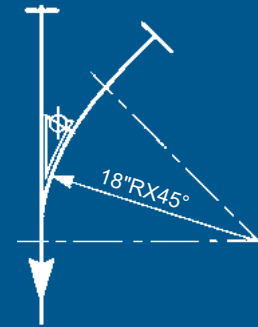

RH Load Switch

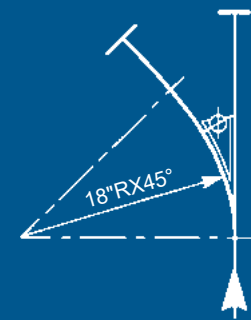

LH Unload Switch

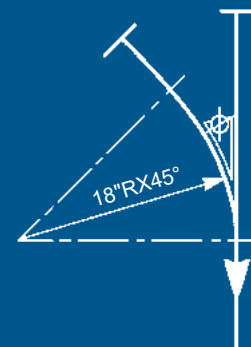

LH Load Switch

Anti-Backup Devices

An anti-backup is a safety device that automatically prevents the reversal of the free trolley.

The unit, which mounts securely on the free track, features a specially designed blade with a beveled front and flat back. In its “closed” position, this blade hangs slightly beneath the track into the conveyor path. When a moving trolley assembly makes contact with the beveled front surface, the anti-backup blade pivots up and out, allowing continued travel. Once the trolley assembly passes, however, the blade pivots back into its closed position - preventing trolley reversal during accumulation or other on-line operations.

Unibilt’s standard steel anti-backups can also be fitted with noise reducing nylon blades.



Standard overhead style steel blade anti-backup



Optional nylon blade anti-backup

Smooth Flow...

Limit Switch Actuators

A limit switch actuator is a control device that helps maintain the smooth flow of production by signaling on-line activity to the main system controls.

Unibilt actuators are constructed of lightweight, durable nylon for easy attachment and repositioning. **For high heat applications, steel actuators are available upon request.** Like anti-backups, these devices hang slightly below the free track to allow contact with passing trolley assemblies. Two basic types of actuator are available:

Momentary Limit Switch Actuators (also called “pork chops”) are designed to be quickly tripped and released by each trolley assembly. This provides the controls with a reliable signal from a carrier, an invaluable tool in maintaining “real-time” system management.

Maintained Limit Switch Actuators (or “ski bars”) feature an extended contact surface that offers sustained contact with the trolley assembly. They are frequently used to indicate that an on-line accumulation area has become full. The actuator signal is electronically relayed to the control panel, causing trailing loads to be stopped or rerouted until the ski bar is released.



Momentary “Pork Chop” design limit switch activator



Maintained “Ski Bar” limit switch activator

All Unibilt switches, stops, and anti-backups are available in both left and right-hand assemblies to meet the specific needs of your application.

Consistent Performance...

Caterpillar Drive Units

Caterpillar Drive Unit 750# Chain Pull Capacity



Weight: 375 lb.

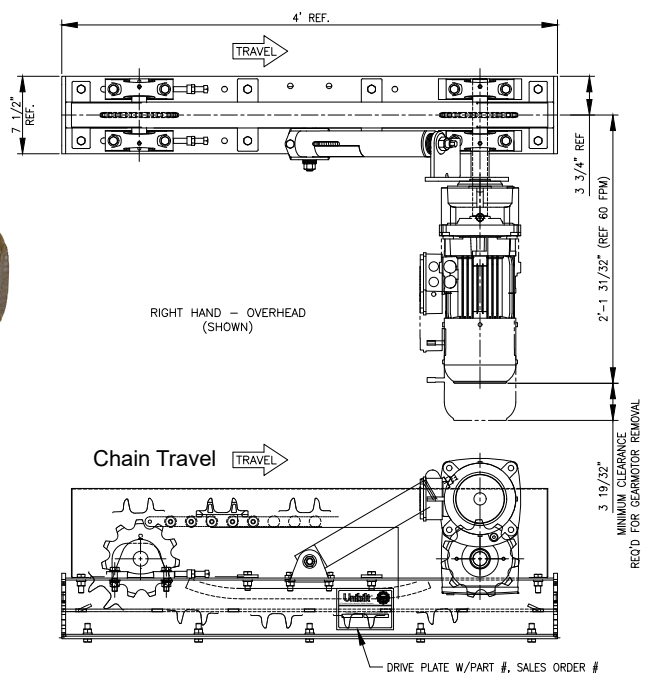

The Unibilt caterpillar drive unit is designed to provide maximum flexibility for all enclosed track power requirements in a single compact package. **Inverted drives are available upon request.**

Many outstanding features make this drive unique in its class.

- The drive has a 750 lb chain pull.
- Constant speed or variable speed available.
Right handed drives are standard.
- Inverter options for achieving intermediate speeds mounts to motor terminal as an option.
- Standard speeds are 5 FPM, 17 FPM, and 60 FPM.
- Guard on drive units comply with applicable OSHA and ANSI B20.1 standards.
- The drive has an electrical automatic overload cut-off device, which is factory adjusted at 1100 lb to stop the motor automatically when an overload or jam condition occurs.
- Multiple drives are required when chain pulls exceed 750 lb. Consult your Webb Regional Manager for multiple drive situations.
- Solid fixed heat-treated steel caterpillar driving dogs eliminate the need for special cams or springs to engage the conveyor chain.
- Fewer parts - direct drive technology eliminates belts and sheaves from the drive, reducing maintenance requirements.
- High-efficiency gear motor with helical bevel gears.
- 1800 RPM, 230/460 volt, 3 phase, 60 hertz, TEFC inverter-duty motors (5:1ratio) are supplied unless otherwise specified.
- Motor controls (push buttons, starters, thermal overloads, etc.) are not included with drives, but can be supplied to your specifications.
- Universal end yokes are provided for convenient hanging. Drive units should be braced adequately to eliminate vibration. Refer to installation methods for hanging and bracing technique.
- Unibilt caterpillar drives permit positioning the drive at the most advantageous location on the system, rather than confining drive location to a horizontal turn, as necessary when driving with a sprocket drive.
- Drive frame and track are painted Unibilt Blue.

Chain Take-Ups

Take-ups maintain proper chain tension by applying a constant force upon the chain as it leaves the drive. This helps ensure smooth conveyor operation, reducing the potential for chain jams and extending component life.

Take-ups are available with pneumatic, counter-weight, and spring operated tension adjustment method, meeting the needs of a wide variety of applications.

Unibilt also offers a full range of specialized take-up assemblies, including: extended travel, large spread, and radius models.

No Slack...



Take-ups are available in several styles, however, spring, counter-weight, and air are most common.

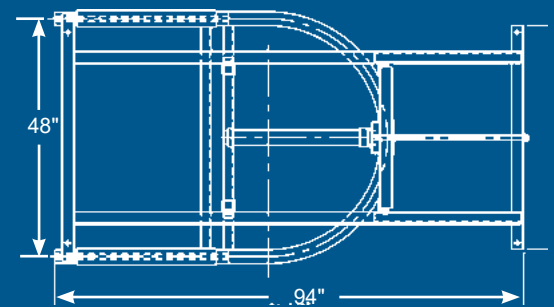
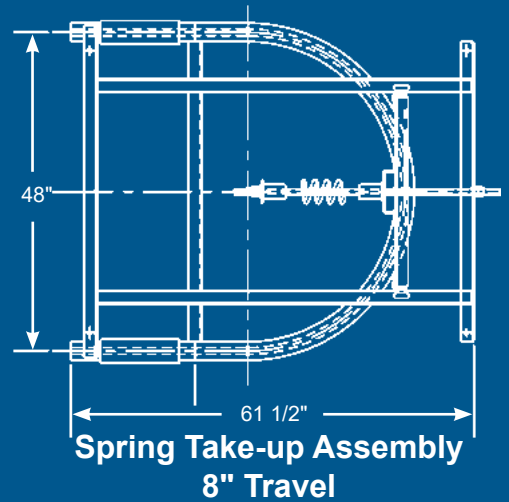

Independent...

Lift Stations

A lift station is a separate section of free track, independent of incoming and outgoing track. Carrier trolleys are moved off of the power & free track and positioned on the lift station track, which is then used to raise or lower the product for various operations (i.e., transfer to another line, inspection, etc.).

Unibilt lift stations are suitable for use in both overhead and inverted conveyor configurations.



Controls

Our control specialists utilize a vast array of technology - including Programmable Logic Controllers (PLCs), Personal Computers (PCs); microprocessors; mini and microcomputers; and exclusive software packages to provide a comprehensive range of controls capabilities.

Our sophisticated, yet user-friendly, supervisory terminals allow “real-time” management of the entire material handling process. By monitoring a selection of displays, operations personnel can efficiently oversee and evaluate system status, then make adjustments accordingly.

Or, in applications requiring highly automated operations work flow can be automatically increased or decreased to match the changing needs of designated production areas.

Inventory management, inter-terminal communication, automatic load identification, and individual load tracking controls can be incorporated into your system.

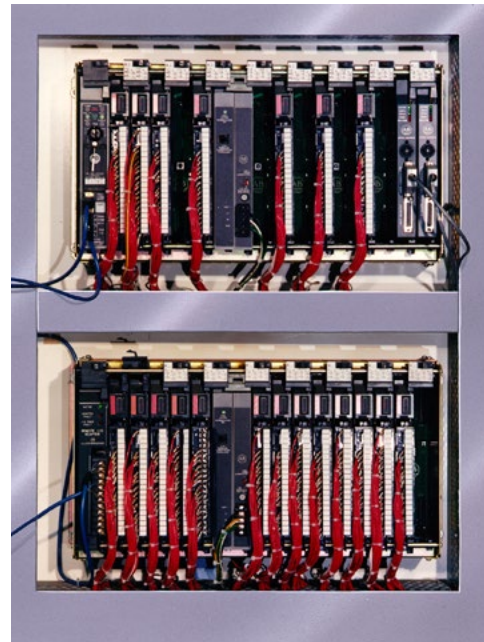

Whatever options you choose, our controls team will work with you to ensure maximum flexibility, productivity, and efficiency.

Support Services

In order for your power & free system to achieve its maximum level of productivity and efficiency, you must feel completely comfortable with all aspects of its operation. That's why, unlike many competitors, Unibilt's involvement doesn't end with the sale.

Contact your local Sales Representative for more information on these and other services.

We offer a complete range of installation, training, and maintenance services to assure that your needs are fully met.

Installation and Commissioning

To ensure the mechanical, electronic, and structural integrity of your new system, all equipment is fully assembled and subjected to rigorous testing *prior* to commissioning.

Training and Documentation

Comprehensive hands-on and classroom training programs can be designed to meet your specific needs. Detailed operation/maintenance manuals and maintenance technician training provide full-time, on-site support. And, our multi-disciplined engineering staff is available to provide professional expertise and support.

Maintenance and Parts

A full range of maintenance and service programs are also available to provide additional support if desired. Plus, with a nationwide network of distributors backed by our 24-hour emergency parts service — replacement parts are just a phone call away.



DAIFUKU

30100 Cabot Drive, Novi, MI 48377 USA
Phone: 1-248-553-1232 Fax: 1-248-553-1253
E-mail: dacproductsales@daifukuna.com
www.Daifuku.com

Your nearest Distributor is:

This brochure is intended to illustrate the various Unibilt conveyor components, accessories and their application into a conveyor system. Environmental, as well as many other conditions, will vary with each installation. Daifuku does not represent, nor warrant that selection of such components or accessories set forth in this catalog will necessarily result in proper selection, manufacture, installation and/or maintenance of conveyor equipment and/or a conveyor system. Daifuku disclaims responsibility for any equipment and/or system malfunction, property damage, personal injury or any other damages of any kind or nature, or violations of law resulting from component, equipment and/or system selection, design, installation, maintenance or operation performed by a contractor, user or any other person.

Data included in this publication is intended only to aid in preliminary evaluations, and is subject to change without notice.

Unibilt® is a trademark of Daifuku or its subsidiary.